

MULTI-FINGER PREHENSION: BIOMECHANICS AND CONTROL

V.M. Zatsiorsky

Department of Kinesiology, The Pennsylvania State University, PA 16802, USA

KEY WORDS: prehension, grasping, finger forces, enslaving, neural network, motor redundancy.

Since 1998 our group published about 20 papers in peer-reviewed journals on biomechanics and control of multi-finger tasks (see a Reference List). The research was done together with Dr. M.L. Latash in cooperation with post-doctoral fellows and graduate students Dr. F. Danion, Z.-M. Li, S.Li, R. Gregory, F.Gao and T.Pataký. The goal of this presentation is to review some of these publications and to report on new results. Many sports—from basketball to javelin throwing and from archery to racket sports—require grasping and manipulation of hand-held objects. Study of multi-finger prehension is an imperative field of research: although human civilization has been built by hands, regrettably we know little about hand functioning. Numerous practical applications of the problem range from clinics and ergonomics to robotics. In multi-finger grasps, the fingers are statically redundant—the number of unknown forces exceeds the number of equilibrium equations—and kinematically over-constrained, a variation in the position of a grasped object affects the position of all the fingers (likewise, a joint angle defines the length of all the muscles crossing the joint). The grasping hand is a convenient object to study the motor redundancy problem because all the involved forces can be directly measured and the sharing pattern easily documented. This is not available when the motor redundancy problem is addressed at the level of individual muscles and their contribution into the total joint torque—a most popular object for studying the sharing problem. Two considerations, a general and a specific one inspired this study. From a general perspective the idea is to study the problem of motor redundancy using the fingers as an expedient object. From a more specific standpoint, hand and finger function by itself is worthy of study.

Force production by several fingers: Isometric force production by several fingers acting in parallel was studied by using the devices shown in Figure 1. The subjects were instructed to produce maximal voluntary contractions (MVC) in one-, two-, three- and four-finger tasks. The following four main phenomena were found/confirmed: (1) *Force sharing*: The total force produced was shared among the fingers in a specific manner. (2) *Force deficit*: The force produced by a given finger in a multiple-finger task was always smaller than the force generated by this finger as a single acting finger. (3) *Force enslaving*: Fingers that were not required to produce any force by instruction were involuntarily activated. (4) *Occlusion*: Enslaving effects from two and three fingers were smaller than the effects from one finger. Two hypotheses were formulated, the *secondary moment hypothesis* to explain the sharing, and the 'ceiling' hypothesis to explain the force deficit. The secondary moment is a moment of force acting on the hand in the segmental transverse plane around a functional neutral longitudinal axis of the hand. Any finger force that does not pass through this axis generates a moment with respect to this axis. The secondary moment is unnecessary for the task; therefore it was hypothesized that the CNS is trying to minimize the secondary moment or bring it to zero. To do that the force-sharing pattern should be selected in a proper way. The 'ceiling' hypothesis is based on the assumption that the central neural drive to the motoneuron pool serving the finger flexors is limited in magnitude. Hence, the larger the number of the involved muscle groups the smaller the amount of drive to a given muscle.

To test the *secondary moment hypothesis*, the maximal grip force was measured with an instrumented handle (Figure 2). In various trials the thumb position was varied. MVC force in a press task was also measured.

The data were in agreement with the *secondary moment hypothesis*. A functional neutral line of the hand exists with respect to which the moment of force in a four-finger press task is zero. In

the gripping tasks, when the thumb was at this line: (a) the moment of normal force and the total shear force were zero; (b) the total normal force applied to the gripping object was maximal; (c) the relative peak normal force—in % of the maximal force exerted by the digit in the single-finger task—was similar for all the fingers; and (d) this position was preferred by the subjects as the most comfortable. In the press task the neutral line was at the same location as in the grip task. It seems that the total force is shared among the individual fingers so as to minimize the secondary moment.

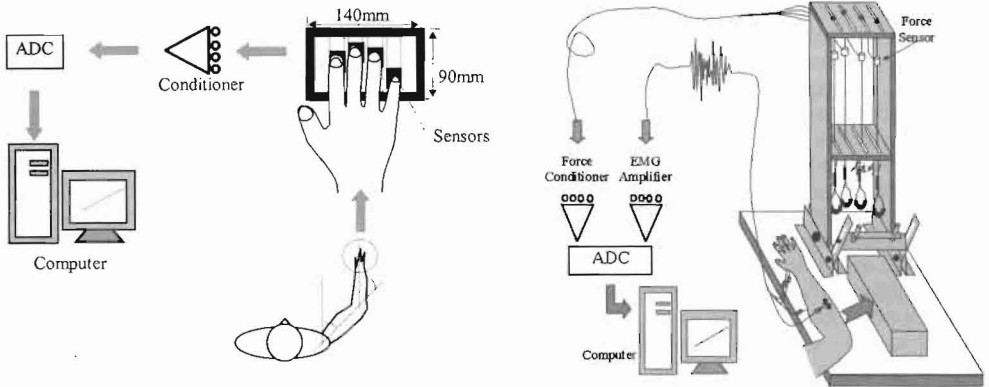

Figure 1. Schematic drawing of the experimental setups. A suspension system shown in the right panel provides two advantages: (a) The direction of the applied finger force is prescribed by the wires and, therefore, the joint moments can easily be computed. (b) The loops for force measurement can be located at different places along the fingers. Therefore the relative contribution of the extrinsic and intrinsic finger flexors into the force production can be controlled.

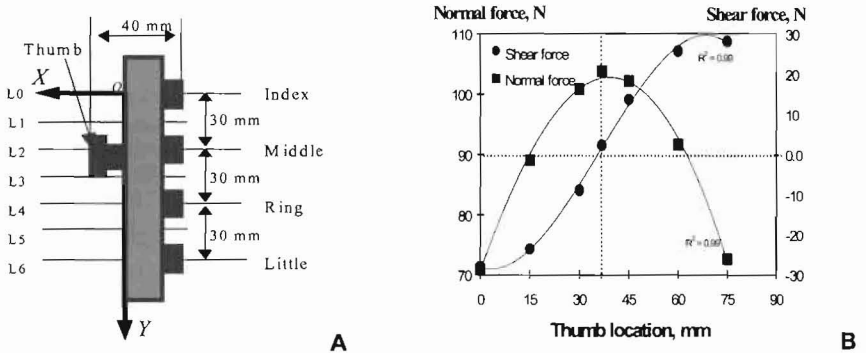

Figure 2. (A) The instrumented handle. The seven locations (L₀ to L₆) for the thumb are shown. The coordinate axis Y originates from the height of the index finger (L₀). The force measured in the X direction was called the *normal force*. The force acting in the Y direction was called the *shear force*. The thumb position varied among the trials. (B) Total normal and shear forces as a function of thumb position. A maximal grip force was produced when the thumb was located at the functional neutral line of the hand, i.e. the line with respect to which the moment of force in a four-finger press task is zero. The normal force was measured and the total shear force was computed from the total torque and normal force.

Finger interaction and neural network modeling (Zatsiorsky, Li, Latash 1998; Z. Li et al. 2002). We studied involuntary force production by individual fingers (*enslaving effects, EE*) during tasks when (an)other finger(s) of the hand generated maximal voluntary pressing force in isometric conditions. The subjects (n=10) were instructed to press as hard as possible on the force sensors with one, two, three and four fingers acting in parallel in all possible combinations. The EE were: (a) large, with the slave fingers always producing a force ranging from 10.9% to 54.7% of the maximal force produced by the finger in the single-finger task; (b) nearly symmetrical; (c) larger for the neighboring fingers; and (d) non-additive. In most cases, the EE from two or three fingers were smaller than the EE from at least one finger (this phenomenon was coined *occlusion*). A neural network model that accounts for all four discovered effects—force sharing, deficit, enslaving, and occlusion—has been developed (Figure 3). The network simulates the muscular apparatus of the hand by having direct projections from the input layer to the output layer (digit-specific intrinsic muscles) and projections via the hidden layer (multi-digit extrinsic muscles). The explicit idea behind the suggested network is that all four reported phenomena—sharing patterns, force deficit, enslaving and occlusion—are consequences of the interconnections among the fingers. These interconnections are both peripheral (at the muscle-tendon level) and central (at the level of the CNS). The central interconnections result in conjoint activation of the compartments of the extrinsic muscles serving different fingers. The model consists of three layers: the input layer that models a central neural drive; the hidden layer that simulates transformation of the central drive into an input signal to the muscles serving several fingers simultaneously (e.g. multi-digit muscles), and the output layer representing finger force output. The output of the hidden layer is set inversely proportional to the number of fingers involved. The network also features direct connections between the input and output layers that represent signals to the hand muscles serving individual fingers (e.g. single-digit muscles). During modeling, the input values (*central commands*) were set either at 1.0 if the finger was intended to produce force or 0.0 if the finger was not intended to produce force.

Output, F_k

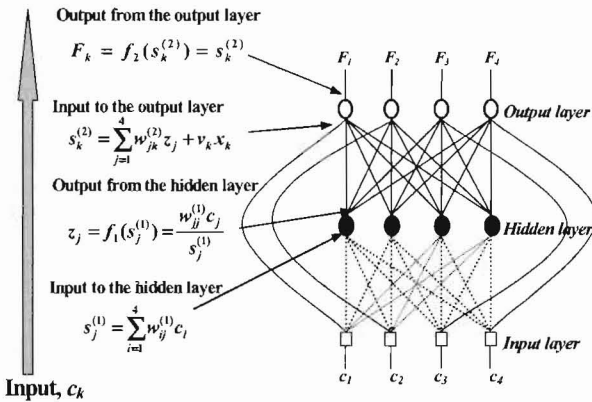

Figure 3. Neural network and the associated mathematical formulations. The index, middle, ring and little finger correspond to 1, 2, 3, and 4, respectively. The mathematical background of the network is explained in Zatsiorsky *et al.* (1998) and Z. Li *et al.* (2001, In press). The network has been validated using three different training sets and worked remarkably well. In all cases, the predicted values were in the range of ± 1 SD.

The neural network yielded a relation between the central commands and the individual finger forces. The relation between the central commands and the finger forces was expressed as a matrix equation:

$$[F] = \frac{1}{n} [w][c] + [v][c] \tag{1}$$

where $[F]$ is a (4×1) vector of the finger forces, $[w]$ is a (4×4) matrix of weight coefficients (the matrix models the multi-digit muscles); $[c]$ is a (4×1) vector of the dimensionless central commands; $[v]$ is a (4×4) diagonal matrix with the gain coefficients that models the input-output relations for the single-digit muscles and n is the number of fingers that are intended to produce

force (for these fingers the central commands =1). For a given n , equation (1) can be simplified to $[F] = [W][c]$ (2)

where $[W]$ is a (4×4) matrix of weight coefficients. From equation (2) it follows that a command c_i sent to finger i ($i=1,2,3,4$) activates to a certain extent all other fingers (*enslaving effects*). A force exerted by a finger i arises from summation of the commands sent to this fingers and to other fingers. The conclusion was made that no direct correspondence exists between neural command to an individual finger and finger force.

Force and torque production in multi-finger tasks: When manipulating a hand-held object, for instance when drinking from a glass, one needs to apply sufficient grip force to prevent the glass from slipping out of the hand. In addition, one needs to control the total torque exerted on the glass such that the glass remains vertical or at a controlled angle that is adequate for drinking and preventing the liquid from being spilled. Usually, the requirements for grip force stabilization allow for some laxity, while the requirements for total torque production are highly specified. As in the example of drinking from a glass, the grip force needs to be larger than the slip threshold and smaller than the force that would break the glass. In contrast, the torque needs to be precisely controlled since any error will lead to rotation of the glass and spilling of the liquid. During manipulation of the glass, the fingers act as *force agonists* and *torque antagonists*. To prevent the glass from slipping, the fingers act as agonists; each of them contributes to the total grip force. In contrast, the index and middle fingers and the ring and little fingers exert moments of force in opposite directions about a pivot point created by the thumb. These two pairs of fingers are torque antagonists. To minimize the total finger force, the fingers that generate a moment opposite to the intended moment should not produce any force. At the same time, to prevent the object from slipping they should generate a force that contributes to the total grip force. These two requirements are contradictory. The central nervous system (CNS) must somehow find a balance between these conflicting requirements. Because a set of five digits is redundant for the control of a hand-held object, the effort can be distributed among the involved fingers in many different ways. The present study addresses forces exerted by five digits on a hand-held object during static force-and-torque production tasks. We are interested primarily in strategies used by the CNS to fulfill the apparently conflicting force and torque production requirements. In experiments, subjects were required to stabilize a handle with an attachment that allowed for independent change of the suspended load and external torque (Figure 4). In some experiments, in addition to the torque, the width of the handle and the thumb location also varied

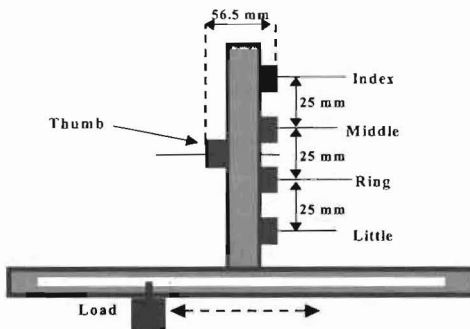

Figure 4. The experimental 'inverted-T' handle. Force sensors were used to register individual digit forces. The suspended load varied from 0.5 kg to 2.0 kg; the load displacement along the horizontal rod created torques from a zero to 1.5 Nm in both directions. Subjects maintained the handle in the upright position using minimal force. The sensors were covered by 100-grit sandpaper (friction coefficient = 1.72). The figure is not to scale.

Force vectors. Examples of the finger force vectors are presented in Figures 5 and 6. In Figure 6 they are shown as force polygons: the vertical downward arrows stand for gravity force, other arrows represent in counterclockwise sequence the force of the thumb, index, middle, ring and little finger, respectively.

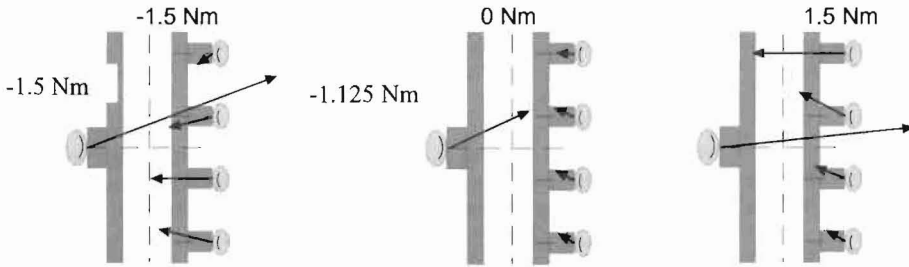

Figure 5. Forces at the digit tips, group average. The supination torque efforts are negative and the pronation torque efforts are positive.

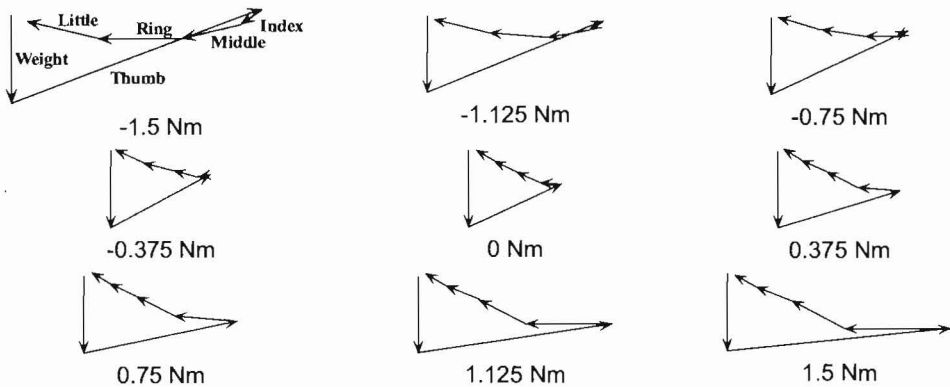

Figure 6. Force polygons. The polygons are obtained by adding tail-to-head the individual forces. Starting from the upper left corner the following forces are shown: gravity, the thumb, index, middle, ring and little finger force.

With the exception of the large (>-0.375 Nm) supination (negative) efforts, the middle, ring and little finger produce forces in the same direction. The force vectors are almost parallel. During the large supination efforts, the forces of the index and middle fingers are directed downward while the forces of the other two fingers are directed upward. The downward forces are, however, small. In all tasks, the index finger does not contribute, or contributes a little, to load holding: the force is directed either horizontally or downward. The finger force direction differs from the direction of other finger force vectors.

Antagonist moments: Individual fingers exerted moments of force in the intended direction of the total moment (*agonist moments*) as well as in the opposite direction (*antagonist moments*), Figure 7. For instance, in tasks requiring pronation moments the index and middle fingers were activated. However, the ring and little fingers were not relaxed; they generated force and produced supination (antagonist) moments. During the 'large load-small torque' tasks, finger forces that generate moments in the intended direction may not be sufficient to prevent slipping of the object out of the hand and, consequently, the 'antagonist' fingers should be activated. The antagonist moments in this case are *mechanically necessitated*. However, the antagonist moments were also observed during the 'small load-large torque' tasks when they were not mechanically necessary.

Optimization: The norms of the following vectors were used as cost functions:

$$(1) \text{ Finger forces } G_1 = \left(\sum_{i=1}^{i=4} (F_i)^p \right)^{1/p} \rightarrow \min$$

- (2) Finger forces normalized with respect to the maximal forces in the single-finger tasks, G_2 .
- (3) Finger forces normalized with respect to the maximal forces in the four-finger (IMRL) task, G_3
- (4) Finger forces normalized with respect to the maximal moments that could be generated by the fingers while grasping an object with four fingers, G_4 .

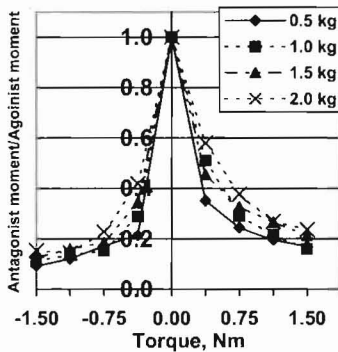

Figure 7. 'Antagonist moment/agonist moment' ratio as a function of torque. When small torques are exerted, the magnitude of the antagonist moment is close to 60% of the agonist moment. It is about 20% during large pronation efforts and it is between 9.2% and 15.4% during large supination efforts. Antagonist moments were observed in the entire range of the torque-load combinations. Hence, some fingers 'work in the wrong direction'. To counterbalance the antagonist moments, the fingers producing moments in the intended direction (*agonist fingers*) should generate larger forces. Such a coordination pattern does not seem optimal.

The power value of the cost functions was selected to be $p=3$ (values of p ranging from 1 to 15 have also been employed but the results will not be presented here). The optimization results were similar, with some small differences, for all four cost functions. For zero torque conditions, all four criteria predicted equal involvement of the finger pairs that generate pronation and supination moments. However, for the non-zero torque conditions, none of the cost functions predicted antagonist moments of force, with the exception of the 2.0 kg/0.375 Nm load/torque combination. This 'large load/small torque' combination corresponds to a force/torque combination where antagonist moments are a mechanical necessity. Hence, criteria based on minimization of finger forces fail to predict the existing antagonist moments observed when they are not mechanically necessary. According to these criteria, the force distribution patterns employed by the subjects were not optimal.

Reconstruction of neural commands and their optimization: The previously described neural network (Figure 3) was used to reconstruct the central commands sent to the individual fingers. Recall, the central commands equal 1.0 if the finger is intended to produce maximal force or 0.0 if the finger is not intended to produce force. The vector of neural commands was computed as $[c] = [W]^{-1}[F]$. The vector $[F]$ was measured in this study. The weight matrix $[W]$ was taken from our previous study on neural network modeling of force production by several fingers (Zatsiorsky *et al.* 1998). The enslaved forces are presented in Figure 8.

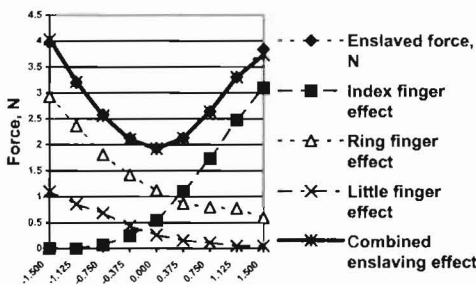

Figure 8. Decomposition of enslaving effects for the middle finger, a 2.0 kg load. The direct finger forces were computed as the product $w_{ij}c_j$ ($i = 1, 2, 3, 4$), where w_{ij} is a diagonal element of the weight matrix. The difference between the actual and 'direct' forces represents enslaving effects, i.e. the force generated by a finger due to the commands sent to other fingers. The force generated by a finger arises from the command sent to this finger ('direct' finger force) as well as from the commands sent to other fingers (enslaved force)

The following objective function was optimized $G_5 = \left(\sum_{i=1}^{i=4} (c_i)^p \right)^{1/p} \rightarrow \min$ where the constraint

$[c] = [W]^{-1}[F]$ was used in addition to the constraints used in the previously described optimization tasks. Overall, the G_5 criterion worked much better than the four criteria based on minimization of finger forces; in particular G_5 always predicted antagonist moments while the other criteria, with a few exceptions, failed to predict them (Figure 9).

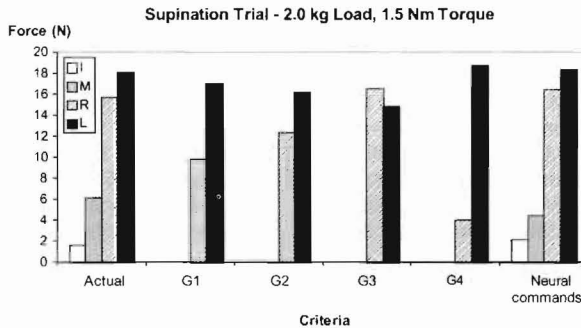

Figure 9. Actual and predicted finger forces.

CONCLUSION: Including into consideration the inter-finger connection matrices (enslaving effects) has substantially improved the accuracy of optimization and allowed for predicting the force sharing patterns in complex force and torque production tasks. Finger enslaving effects can be viewed as an example of built-in relations among outputs of individual effectors in multi-effector tasks.

REFERENCES:

- Danion F, Latash M, and Zatsiorsky V (1999) Effects of single and multi-finger prolonged exercise on multi-finger coordination. In *From Basic Motor Control to Functional Recovery* (Edited by Gantchev N and Gantchev GN) 353-357. Academic Publishing House "Prof. M. Drinov", Sofia.
- Danion, F., Latash, M.L., Li, Z.M., and Zatsiorsky, V.M. (2001) The effect of a fatiguing exercise by the index finger on single- and multi-finger force production tasks. *Experimental Brain Research* **138**, 322-9.
- Danion F, Latash ML., Li ZM, and Zatsiorsky VM . The effect of fatigue on multifinger coordination in force production tasks in humans. *Journal of Physiology* (London) 523[Pt 2], 523-532. 2000.
- Latash, M.L., Li, S., Danion, F., and Zatsiorsky, V.M. (2002) Central mechanisms of finger interaction during one- and two-hand force production at distal and proximal phalanges. *Brain Research* **924**, 198-208.
- Latash ML , Gelfand IM, Li ZM , and Zatsiorsky VM (1998) . Changes in the force-sharing pattern induced by modifications of visual feedback during force production by a set of fingers. *Experimental Brain Research* **123**(3), 255-62.
- Latash ML, Li ZM, and Zatsiorsky VM (1998) A principle of error compensation studied with a task of force production by a redundant set of fingers. *Experimental Brain Research*, **122**, 131-138.
- Li, S., Danion, F., Latash, M.L., Li, Z.M., and Zatsiorsky, V.M. (2001) Bilateral deficit and symmetry in finger force production during two- hand multifinger tasks. *Experimental Brain Research* **141**, 530-40.

- Li S, Danion F, Latash ML, Li ZM, and Zatsiorsky VM (2001) Bilateral deficit and symmetry in finger force production during two-hand multifinger tasks. *Experimental Brain Research* **141**, 530-540.
- Li S, Danion F, Latash ML, Li ZM, and Zatsiorsky VM (2000) Finger coordination and bilateral deficit during two-hand force production tasks performed by right-handed subjects. *Journal of Applied Biomechanics* **16**, 379-391.
- Li, Z.M., Zatsiorsky, V.M., Li, S., Danion, F., and Latash, M.L. (2001) Bilateral multifinger deficits in symmetric key-pressing tasks. *Experimental Brain Research* **140**, 86-94.
- Li ZM, Latash ML, and Zatsiorsky VM (1998a) Force sharing among fingers as a model of the redundancy problem. *Experimental Brain Research* **119**(3), 276-86.
- Li ZM, Latash ML, Newell KM, and Zatsiorsky VM (1998b) Motor redundancy during maximal voluntary contraction in four-finger tasks. *Experimental Brain Research*, **122**, 71-7.
- Li, Z., Zatsiorsky, V.M., and Latash, M.L. (2001) The effect of finger extensor mechanism on the flexor force during isometric tasks. *Journal of Biomechanics*, **34**, 1097-102.
- Li ZM, Zatsiorsky VM, and Latash ML (2000) Contribution of the extrinsic and intrinsic hand muscles to the moments in finger joints. *Clinical Biomechanics*, **15**, 203-211.
- Li ZM, Zatsiorsky VM, Latash ML, Bose NK (2002) Anatomically and experimentally based neural networks modeling force coordination in static multi-finger tasks. *Neurocomputing (in press)*.
- Zatsiorsky, V.M., Li, Z.M., and Latash, M.L. (2000) Enslaving effects in multi-finger force production. *Experimental Brain Research*, **131**, 187-95.
- Zatsiorsky VM, Li ZM, and Latash ML. Enslaving effects in multi-finger force production. *Experimental Brain Research*, **131**(2), 187-95. 2000.
- Zatsiorsky VM, Gregory RW, Latash ML (2002) Force and torque production in static-multi finger prehension: Biomechanics and control. *Biological Cybernetics* (In press)