

THE CONTRIBUTION OF THE FLIGHT PHASE IN ELITE RACE WALKING

Brian Hanley¹, Athanassios Bissas¹ and Andrew Drake²

Carnegie Research Institute, Leeds Beckett University, Leeds, UK¹
National Centre for Race Walking, Leeds Beckett University, Leeds, UK²

Although race walkers are not permitted a visible flight phase, previous research has found that most competitors do experience very brief losses of contact. The purpose of this study was to assess the role of the flight phase in elite race walking. Seventeen international athletes race walked over two force plates recording at 1000 Hz. Video data were simultaneously recorded at 100 Hz and used to calculate kinematic variables such as step length. The mean flight time was 0.030 s (\pm .011) while the mean distance travelled during this phase was 0.12 m (\pm .05). It was calculated that without flight times, athletes would have slower mean velocities, particularly if mean cadence remained the same. However, the contribution of flight phases in race walking does not just allow for greater step lengths and faster speeds, but also more time for lower limb repositioning.

KEY WORDS: athletics, elite sportspeople, gait, kinematics.

INTRODUCTION: According to IAAF Rule 230.1, "Race walking is a progression of steps so taken that the walker makes contact with the ground, so that no visible (to the human eye) loss of contact occurs. The advancing leg must be straightened (i.e. not bent at the knee) from the moment of first contact with the ground until the vertical upright position". A flight phase is one feature that distinguishes running from normal walking, and IAAF Rule 230.1 is an attempt to maintain this conceptual difference. However, previous research on race walking in competition and during laboratory testing has found that brief flight phases are common to practically all elite race walkers (Hanley & Bissas, 2013; Hanley, Bissas & Drake, 2011, 2013). Previous mathematical models have been used to predict maximum race walking speed in the absence of a flight phase. For example, in Figure 1, L_A represents the actual length of a race walker's leg; while L_{EFF} is the increased, 'effective' leg length achieved with pelvic rotation ('a' represents the resulting distance between the hip joints caused by this pelvic rotation). Step length can thus be calculated as $[2 \times (L_A \times \cos\theta) + a]$ (Trowbridge, 1981). In the diagram, θ represents the angle between the leg and the ground and is assumed to be the same for both legs at double support (and L_A is assumed to be the same for both the front and rear legs). While Trowbridge's model has been used as evidence that race walkers cannot possibly achieve their competitive speeds without loss of contact, its weaknesses include an assumption that the push-off leg is straight (which is what allows θ to be equal for both legs), even though race walkers need to maintain a straightened knee until midstance only, and that it was not based on actual race walking measurements.

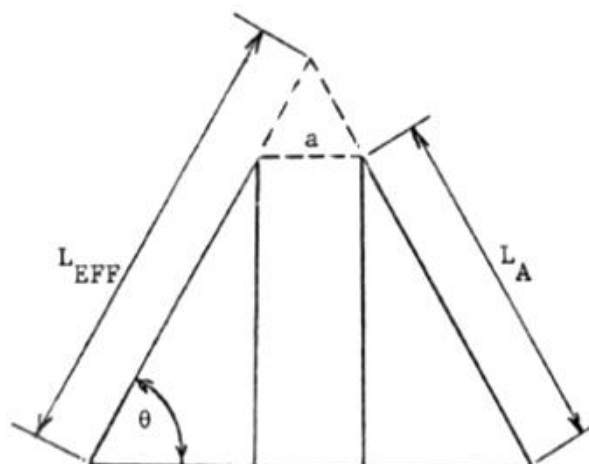

Figure 1: A model of calculating step length in race walking (Trowbridge, 1981).

While there is no prescribed limit of what constitutes loss of contact except as a subjective 'visible' occurrence, reporting typical flight times of elite athletes and those tested in laboratory studies is invaluable to the coach (and judge) who is interested in appreciating what actual flight durations occur, and to the researcher of race walking who is keen to ensure external validity. The aim of this study was to measure and evaluate the role of the flight phase in male and female elite race walkers.

METHODS: The study was approved by the Faculty Research Ethics Committee and 17 race walkers gave written informed consent. The athletes comprised 10 men (26 ± 3 yrs, $1.79 \pm .05$ m, 67.1 ± 7.9 kg) and seven women (26 ± 5 yrs, $1.66 \pm .05$ m, 55.8 ± 4.8 kg). All athletes had competed at the Olympic Games or World Championships. All 10 men had previously competed over 20 km (personal best time: $1:23:29 \pm 1:59$) with eight also competing over 50 km ($3:52:59 \pm 6:23$). The mean personal best time for the women over their competitive distance of 20 km was $1:30:55 (\pm 1:47)$. Each athlete race walked along a 45 m indoor running track at a speed equivalent to their season's best time (20 km or 50 km for men dependent on specialism). Timing gates were placed 4 m apart around two force plates (Kistler, Winterthur) that recorded both left and right foot contact phases and flight time. Athletes completed at least ten trials and the three closest to the target time were analysed (provided they were within 3% of the target time). The force plates recorded at 1000 Hz and were placed in a customised housing in the centre of the track. Contact time was considered to begin when the vertical force trace exceeded 5 N and to end when it decreased below 5 N again; flight time was calculated as the time between steps.

Video data were collected at 100 Hz using a high-speed camera (Fastec, San Diego, CA). The shutter speed was $1/500$ s, the f -stop was 2.0, and there was no gain. The camera was placed approximately 12 m from and perpendicular to the line of walking. The resolution of the camera was 1280 x 1024 pixels. The force plate software and the camera system were synchronised using a Kistler connection box (Kistler, Winterthur). The GRF data were smoothed using a recursive second-order, low-pass Butterworth filter at 50 Hz.

The video files were manually digitised by a single experienced operator to obtain kinematic data (SIMI Motion, Munich). Digitising was started at least 10 frames before the beginning of the stride and completed at least 10 frames after to provide padding during filtering. The magnification tool in SIMI Motion was set at 400% to aid identification of body landmarks. De Leva's (1996) body segment parameter models were used to obtain data for the whole body centre of mass and all body segments. Noise was removed using a Butterworth low-pass filter, with the cut-off frequencies calculated using residual analysis (Winter, 2005).

Race walking speed was determined as the mean horizontal speed of the centre of mass during one complete gait cycle (using the digitised data). Step length was measured as the distance between successive foot contacts using the digitised data. Because of differing standing heights of participants, step length was also normalised by expressing as a percentage of the participants' statures, and referred to as step length ratio. Cadence was calculated by dividing horizontal speed by step length. The distance the whole body centre of mass travelled during flight was measured from the instant of toe-off of one foot to the instant of initial contact of the other and termed flight distance. With regard to angular kinematics, the knee angle was calculated as the sagittal plane angle between the thigh and leg segments and was considered to be 180° in the anatomical standing position. The hip angle was defined as the sagittal plane angle between the trunk and thigh segments and was also considered to be 180° in the anatomical standing position. The ankle angle was calculated in a clockwise direction using the lower leg and foot segments and considered to be 110° in the anatomical standing position. Pearson's product moment correlation coefficient was used to find associations between key spatiotemporal variables. In addition, to further highlight the contribution of flight time to elite race walking, hypothetical values for step length and cadence (and hence speed) were calculated based on the removal of flight time with regard to its effect on these key spatiotemporal variables ('No flight phase') and in terms the effect of absorbing flight time into contact time on these same variables ('No flight / cadence maintained').

RESULTS: The main spatiotemporal results are shown in Table 1 ('Actual') along with hypothetical values based first on the absence of flight time (but with no change in contact time: 'No flight phase'), and second with an absence of flight time (but with a contact time that absorbs the original duration of flight: 'No flight / cadence maintained').

Table 1 Actual and hypothetical spatiotemporal variables of race walking (mean \pm SD)

| | Actual | No flight phase | No flight / cadence maintained |
|-----------------------|--------------------|--------------------|--------------------------------|
| Flight time (s) | .030 (\pm .011) | - | - |
| Flight distance (m) | 0.12 (\pm .05) | - | - |
| Step length (m) | 1.16 (\pm .08) | 1.04 (\pm .08) | 1.04 (\pm .08) |
| Step length ratio (%) | 132.8 (\pm 7.6) | 118.8 (\pm 6.6) | 118.8 (\pm 6.6) |
| Contact time (s) | .283 (\pm .018) | .283 (\pm .018) | .313 (\pm .012) |
| Cadence (Hz) | 3.20 (\pm .12) | 3.55 (\pm .21) | 3.20 (\pm .12) |
| Speed (km/h) | 13.37 (\pm .74) | 13.25 (\pm .80) | 11.95 (\pm .59) |

In actual terms, flight distance contributed approximately 10% of total step length. Speed was correlated with step length ratio ($r = .73$, $p = .001$), flight time ($r = .52$, $p = .031$) and flight distance ($r = .66$, $p = .004$). Step length ratio was correlated with flight distance ($r = .52$, $p = .034$). Cadence was negatively correlated with contact time ($r = -.81$, $p < .001$), while flight distance was positively correlated with flight time ($r = .85$, $p < .001$). The mean hip angle at initial contact was $170^\circ (\pm 2)$ while at toe-off it was $185^\circ (\pm 3)$. The mean knee angle at initial contact was $180^\circ (\pm 2)$ while it was $149^\circ (\pm 5)$ at toe-off. The mean ankle angles at initial contact and toe-off were $90^\circ (\pm 4)$ and $127^\circ (\pm 6)$ respectively.

DISCUSSION: Flight times occurred in all 17 participants, with longer flight times associated with higher walking speeds and longer steps. More importantly, the resulting longer flight distances were therefore also a reason for overall greater step lengths. It is thus very clear that the brief (but probably non-visible) flight phases that elite race walkers undertake are an important factor in their performances. This was emphasised by the hypothetical values that were predicted based on the removal of the flight phase; step lengths would have been an average of 12 cm shorter, while the concurrent reduction in step time would have resulted in mean cadences of 3.55 Hz (213 steps per minute) that are far higher than those reported of world-class race walkers in competition (Hanley, Bissas & Drake, 2011). However, such an eventuality would lead to decreases in walking speed of only 0.12 km/h. Nonetheless, the high cadences required would be unachievable by most race walkers and maintenance of the same cadence would be more likely (i.e. by spending the duration of flight time in double support instead). This hypothetical eventuality would lead to very large decreases in speed (by a mean of 1.42 km/h) in this group of athletes that would have considerable negative consequences in competition. Modelling of race walking has suggested that it is difficult to achieve speeds above 7.4 km/h without loss of contact (although pelvic rotation could increase step length by increasing the functional length of the leg) (Trowbridge, 1981). However, an increase in step length is possible beyond what was predicted in the model because of knee flexion during late stance (the mean knee angle at toe-off was 149° in this study). In this way, elite race walkers are able to achieve longer steps than those predicted by Trowbridge (1981) who, by assuming the rear leg stayed straightened after midstance, did not take into account the extra distance gained by either the small amount of knee hyperextension at initial contact that sometimes occurs or the considerably greater degree of knee flexion at toe-off (Figure 2). Therefore it is not the flight phases only that allow for longer steps as joint kinematics also contribute.

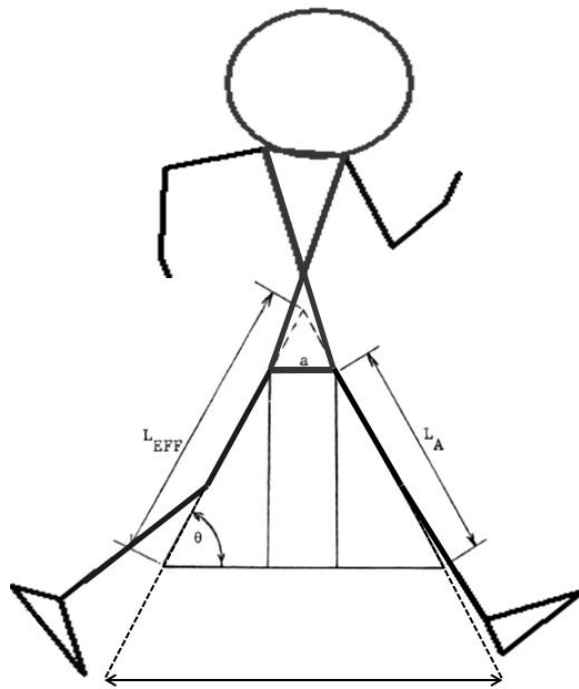

Figure 2: Trowbridge's model of step length with a digitised figure of an elite race walker superimposed. The dashed lines are extrapolations of the original L_{EFF} and L_A lines because the diagram has been rescaled to match the distance between the digitised hip joints ('a').

From a coaching viewpoint, flight time was an important contributor to step length by way of flight distance, and there might be a temptation for athletes to deliberately increase it. However, the risk of having too long a flight phase is clear and it is not sensible to explicitly advise race walkers to increase its length in an attempt to improve performance. On the contrary, it is preferable for them to develop their techniques in such a way that high speeds are maintained with as little flight as possible. One way in which this might be achieved is through increasing step length via the knee flexion movement that occurs in late stance.

CONCLUSION: The aim of this study was to measure and evaluate the role of the flight phase in elite race walkers. Overall, it was clear that these elite race walkers relied on relatively long flight times for a large component of step length, and without these flight periods the athletes would have been considerably slower. In effect it is not possible for elite race walkers to obtain the speeds required for world-class competition without some duration of flight. It is possible that these flight phases, which if long enough to be visible can lead to disqualification, would be even longer without the knee flexion that occurs during late stance.

REFERENCES:

- de Leva, P. (1996). Adjustments to Zatsiorsky-Seluyanov's segment inertia parameters. *Journal of Biomechanics*, 29, 1223-1230.
- Hanley, B., Bissas, A. & Drake, A. (2011). Kinematic characteristics of elite men's and women's 20 km race walking and their variation during the race. *Sports Biomechanics*, 10, 110-124.
- Hanley, B., Bissas, A. & Drake, A. (2013). Kinematic characteristics of elite men's 50 km race walking. *European Journal of Sport Science*, 13, 272-279.
- Hanley, B. & Bissas, A. (2013). Analysis of lower limb internal kinetics and electromyography in elite race walking. *Journal of Sports Sciences*, 31, 1222-1232.
- Trowbridge, E.A. (1981). Walking or running - when does lifting occur? *Athletics Coach*, 15(1), 2-6.