

---

# The Effects of Stance on Bat Kinematics and Ground Reaction Forces in Hitting

---

*G. Wayne Marino*  
*Department of Kinesiology*  
*University of Windsor*  
*Windsor, Ontario, N9B 3P4*  
*Canada*

It has been suggested (Hay, 1978) that variations in batting stance influence two important determinants in the skill of hitting a baseball (swing time and bat speed). Although data appear to be unavailable, a closed stance (front foot closer to home plate than the back foot) has been described as requiring a longer swing time and producing a higher bat speed. The open stance (front foot farther from home plate than the back foot) reportedly produces faster swings. Finally, a square stance (feet equidistant from home plate) is said to offer a compromise producing a combination of a relatively short swing time and a relatively high bat speed.

In addition to speculation on the effects of stance on bat kinematics, data have been reported relating both stance and swing to batting performance. Adams (1965) studied twelve hitters and reported that the open stance resulted in significantly fewer strikeouts than the closed stance. The enhanced performance of the open stance was attributed, in part, to the fact that it afforded the batter a better view of the ball as it left the pitcher's hand and travelled toward home plate. Marino and Noble (1983), reported on the swing characteristics of forty-six subjects. Results indicated that statistically a significant relationship ( $r = -.44$ ) existed between swing time and batting average in international level play. There was, however, no statistically significant relationship ( $r = -.14$ ) between batting average and the total time of the movement pattern including both stride and swing.

**McIntyre** and Pfautsch (1982) presented data on swing times and bat speeds of swings designed to result in either same-field or opposite-field hits. Swing time was found to be significantly shorter ( $X = .125s$  vs  $X = .142s$ ) for opposite field hits. The linear velocity of the end of the bat was found to be slightly higher for same-field hits (39 **m/s** vs 36 **ll m/s**) but the differences were not statistically significant. These differences were attributed to the slightly shorter radius of rotation found for opposite-field hits.

A complex, three dimensional technique used by Shapiro (1979) resulted in data detailing swing characteristics of one highly skilled **inter-collegiate** level player. Maximum bat velocities ranging from 26.08 **m/s** to 34.67 **m/s** were reported. In 67% of the trials studied, maximum velocity occurred at the instant of contact.

In a recent study, Hirano (1987) investigated the batting swing kinematics and bat kinetics of five skilled and two unskilled college baseball players. Subjects were fitted with celluloid tape to ascertain hip rotation and high speed cinematography was used to measure bat movements. The mean velocity of the bat impact point was found to be 31.14 **m/s** for the skilled subjects and 27.7 **m/s** for the unskilled. Also, it was determined that the skilled subjects attained significantly higher total energy values during the swing (274.0J vs 227.5J) and that these differences were attributable to differences in the linear kinetic energy component.

Messier and Owen (1984) studied highly skilled female softball players hitting a pitched ball with a standard aluminium softball bat. Two cameras were employed to generate three dimensional data and results indicated a mean resultant bat velocity of 19.08 **m/s**. Also, kinetic energy (KE) levels of the bat were determined and results revealed a maximum KE of 161.69 J, 59.8% of which was linear in origin and 40.2% rotational. The softball batting stride as employed by highly skilled females was also studied by Messier (1984) who determined the effects of stride characteristics on bat velocity. Although differences in bat displacement were reported, there were no significant differences found in bat velocity when closed, open parallel (square) stances were used.

Thomas (1987) speculated without giving evidence on the weight distribution of a batter. It was suggested that the initial stance is critical to the nature of the swing and that the batter usually assumes a stance with approximately 60% of the weight resting on the rear foot.

The ground reaction forces created by female softball batters were studied by Messier and Owen (1985). Front and rear foot forces were recorded during separate swings as only one force platform was utilized.

Allbatters were right handed hitters. Rear foot vertical forces were found to increase to approximately body weight during the stride and to fall to about **43%** of body weight by the completion of the stride. The mediolateral forces acting on the rear leg reached a maximum of 40% of body weight in the backward direction. This force was said to initiate the forward movement during the stride. In the anteroposterior direction, rear foot forces were directed backward and ranged from about **20%** to **40%** of body weight. It was speculated that along with the antero-posterior forces exerted on the front foot, these serve to rotate the hips and upper body.

In summary, although considerable attention has been paid to baseball batting swing characteristics, it appears that further work is required to fully document evidence describing the effects of batting stance on force production. Also, no data are available concerning the possible effects of stance related differences on right vs left handed hitters. Thus, the purpose of this study was to investigate the effects of stance variations on selected kinematic and kinetic parameters of the baseball batting swing.

## **METHODS**

Ten members of the **1984** Canadian Olympic Baseball Team were tested in a laboratory setting. Each subject was given ample time to practice the required movements in an attempt to minimize practice effects. Three stance positions (square, closed and open) represented different levels of the independent variable stance. The dependent variables measured included: A) total movement time (including stride and swing), B) swing time, C) linear velocity of the impact point of the bat at the instant of **ball**-bat contact, and D) the ground reaction forces generated by the back foot, in three orthogonal directions, during the batting movements of right and left handed hitters.

Ground reaction forces acting on the back foot during the swing and impact were recorded. Figure 1 shows a schematic diagram of the home plate **area** and indicates the sign conventions used for the lateral and anteroposterior force measurements.

As is evident, the major difference that should be noted occurred in the anteroposterior ground force which was exerted perpendicular to the side of the home plate. For a right handed batter, this force was positive when a step toward the plate was taken and negative when a step away from the plate was taken. The results were reversed for a left handed batter.

As testing commenced, each subject assumed a batting stance with the back foot resting on an A.M.T.I. (Advanced Mechanical Technology Inc.)

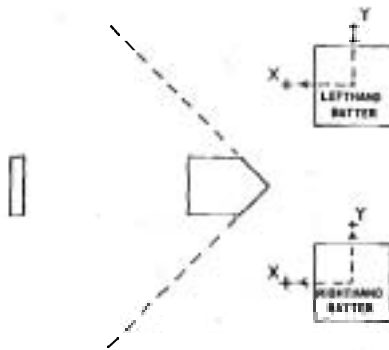

X. REPRESENTS A LATERAL FORCE IN THE  
FRONTAL PLANE EXERTED // THE SIDE OF  
HOME PLATE

Y. REPRESENTS AN ANTEROPOSTERIOR FORCE  
IN THE SAGGITAL PLANE EXERTED  $\perp$  THE  
SIDE OF HOME PLATE.

Figure 1: Sign conventions for Ground Reaction Forces

Computerized Biomechanics Platform. The force platform was programmed to sample ground reaction forces for a maximum of 10 seconds at 100 Hz. Subsequently, the time base was scaled to include only the actual preparation period of the hitter and the swing. The force data were filtered through use of a fourth-order, low pass, digital filter in the A.M.T.I. software package. Each subject assumed what they considered to be a closed, open or square stance and the order of closed, open and square stance trials was randomly selected for each subject. All subjects were tested twice using all three stances in a repeated measures design. The data reported in the results section of this paper represent the means of two trials per subject in each stance position.

When each subject had assumed a comfortable stance, a ball was tossed into the hitting area. The toss was made from behind a screen and at a speed and distance predetermined to simulate the time for a normal pitch of 128 kilometres per hour to travel from the pitcher's mound to home plate. If the toss was suitable, the subject swung and hit the ball into a mesh, netting. Each trial was filmed from an overhead view using a Locam 16 mm camera operating at 200 frames per second. The optical axis of the lens

was set perpendicular to the ground and the field of view was large enough to include the whole stride and swing as well as the contact point and some followthrough. Simultaneously, data from the force platform system were recorded directly by an "on line" Northstar Horizon microcomputer. The camera and force plate time bases were synchronized by **identifying** common events (i.e., stepping on and off the platform) and interpolating the film time base to correspond to that of the force platform.

Subsequent to **testing**, collection of kinematic data from film was facilitated through use of Numonics Graphics Calculator and Apple II microcomputer system.

Swing time was defined as the time from initiation of the stride to the point of impact. Stride time began at the start of the forward stride and ended when the front foot re-established ground contact and finally; bat time was measured as the time from **first** perceptible movement of the bat to the point of impact. In each case, the time base from the film was used to calculate these temporal parameters. Linear bat velocity at impact was determined by first locating the impact point on the bat. The film was then reversed until the start of bat movement was apparent and the coordinates of the impact point at each frame leading up to impact and several frames beyond were filtered using a Butterworth, low pass, fourth-order digital filter. The smoothed data were then used to calculate linear velocity of the impact point of the bat at the point of ball contact.

A modified version of an A.M.T.I. software package designed to assess gait was used to collect ground reaction force data from the back foot during each swing analysed. In addition to the actual force-time curves, maximum and minimum forces along three orthogonal axes were recorded.

Temporal and kinematic data were grouped for all subjects and subjected to Analysis of Variance with Repeated Measures in order to identify statistically significant differences between stances. Assessment of ground reaction forces required a more specific separation of subjects into right and left handed hitters. This was necessary to account for sign convention differences in the force data. For example, right handed batter stepping away from home plate (open stance) would normally produce a negative ground reaction force in the anteroposterior direction. In contrast, for a left handed batter to produce a similar force, the step would have to be toward home plate (closed stance). Force and impulse data, therefore, were subjected to a two-way Analysis of Variance with repeated measures in order to test for significant differences between both batting stance and handedness. In each case, statistically significant differences were accepted at  $P \leq .05$ .

## RESULTS

Temporal and kinematic variable means for each stance condition are listed in Table 1.

TABLE 1

Mean Temporal and Kinematic Characteristics of Batting Performance Using Three Stances  
(N = 10)

Variable	Stance		
	Square	Closed	Open
Total Swing Time (s)	.51	.52	.49
Stride Time (s)	.32	.32	.31
Bat Time (s)	.20	.21	.19
Bat Velocity (m/s) at Impact	23.8	24.7	24.4

The total swing time was slightly shorter for the open stance than for the other two ( $X$  open = .49s,  $X$  square = .51s, and  $X$  closed = .52s). In addition, the bat time (from commitment to swing until impact) was slightly smaller for the open stance (.19s vs .20s and .21s). These trends would have been expected based on the literature review. However, due to the combined effects of the small number of subjects and high variability, none of the differences met the criterion for statistical significance. In effect, based on the results of this study, it appeared that stance had no effect on how quickly a hitter got the bat into the hitting area. Finally, no trends were found in the mean bat velocities at the point of impact. In fact, both the closed ( $X = 24.7$  m/s) and open ( $X = 24.4$  m/s) stances produced slightly higher velocities than the square stance ( $X = 23.8$  m/s). Once again, none of the observed differences were found to be statistically significant. The results of this study indicated, therefore, that bat velocity was unaffected by stance.

In assessing forces it was determined that no statistically significant differences occurred either between stances or between left and right handed batters in the maximum vertical or lateral forces exerted during the swing. The mean vertical maxima recorded on the ten subjects for the square, closed and open stances were  $X = 894$  N,  $X = 865$  N, and  $X = 918.5$  N, respectively, and the mean maxima of the lateral forces were  $X = 237.4$  N,  $X = 221.5$  N, and  $X = 228.7$  N, respectively.

When anteroposterior forces were assessed, position relative to home plate had to be taken into account. The force data for this variable are listed in Table 2.

**TABLE 2**

**Anteroposterior Ground Reaction Forces**  
Recorded on Right Handed and Left Handed  
Batters Using the Three Different Stances

Stance	Left Handed*	Batters Right Handed*
	(N = 5)	(N = 5)
Square	-194.3N	186.4N
Closed	-245.3N	237.8N
Open	257.5N	32.4N

\*Significant Between Stance Differences at  $P < .05$

Note: Significant Interaction Exists at  $P < .05$ .

It was found that when using either a square or a closed stance, left handed batters created large negative ground reaction forces in the anteroposterior direction while right handed batters using the same stances produced large positive forces. In contrast, when using an open stance, left handed batters produced large positive anteroposterior forces. The mean value for the right handed group in this study was small since three of the subjects produced negative forces and the other two positive forces. Two Way Analysis of Variance revealed that statistically significant differences existed between stances for both right and left handed groups ( $F = 12.36$ ). In addition, as would be expected, there was a statistically **significant** interaction effect ( $F = 9.21$ ). This indicated that the nature of the anteroposterior force maxima depended not only on the type of stance employed, but also on the handedness of the batter.

From a practical viewpoint, these data may be of some significance in the offensive (hitting and baserunnings) phase of the game of baseball. When combined with the positive lateral force vectors evident in all strides from all three stances, the anteroposterior force vector produces either movement toward first base (positive anteroposterior) or toward third base (negative anteroposterior). Therefore, since one of the batter's objectives is a quick start toward first base, it might be possible to enhance this start by using a particular stance. For example, a left handed batter

using an open stance may be able to leave the batter's box with greater momentum toward first base than another batter using either a closed or even square stance. It is theoretically possible that some ground outs could be turned into base hits. In contrast, a right handed hitter might create a more effective movement toward first base through use of a closed or square stance rather than an open one. Since quickness out of the batter's box was not tested in this study, this discussion is hypothetical but the possible advantages are significant enough to warrant investigation.

The hypothesis that stance can affect quickness of movement out of the batter's box and momentum toward first base neglects the other stated advantages of various stances. However, the data from this study indicate that no between stance differences exist in any of the temporal or kinematic variables measured including swing time and bat velocity. The other main advantage of various stances, the ability to see the ball better, has not been considered here.

## SUMMARY AND CONCLUSIONS

In summary, a laboratory study was designed to evaluate batting characteristics of elite amateur baseball players. Ten member (five right handed and five left handed batters) of the 1984 Canadian National and Olympic Team were tested while hitting tossed baseballs into a net. Each of the batters used square, closed and open stances in randomly selected order. Data collection was facilitated through use of high speed film and force platform system capable of recording ground reaction forces acting on the back foot during the stride and swing. Both kinematic and kinetic variables of interest were measured.

Analysis of the results led to some conclusions that did not support earlier literature on hitting. For example, it had been felt that differences existed in both quickness of the swing and bat velocity at impact between the three stances studied. Data from this laboratory investigation did not support that contention. However, since no differences in these temporal and kinematic variables were found, it was possible to look at other potential advantages of each of the stances. It was found that right handed batters using either square or closed stances produced forces that might facilitate quickness and high velocity in their starts toward first base following contact with the ball. In contrast, left handed batters, to gain this advantage, would have to use an open stance.

Interpretations of the data from this study must be made in light of certain limitations. Since the toss was made from a relatively short distance,



there was very little uncertainty regarding location. Also, the batter did not have to worry about lateral movements (curving) of the ball and timing was not a significant problem (only one toss was missed entirely and a few others were fouled either up or down). No consideration was given to hit location. Subjectively, however, it appeared that most hits would have been **"up-the-middle"** with a few being "pulled" and a few hit to the "opposite field". Finally, since the testing area was somewhat **confined**, no attempt was made to measure the quickness or velocity of movements toward first base following a hit.

In conclusion, the data from this study suggests that stance has little impact on bat characteristics in hitting. It does, however, suggest that stance may influence the effectiveness of the batter's start toward first base. The nature of the testing protocol would render these conclusions somewhat premature. It seems more appropriate to suggest that similar testing should be conducted on a baseball diamond under either game or simulated game conditions. Also, the effects of eye dominance and the varying sight lines afforded by each of the stances should be more fully investigated. Finally, further investigation of the effects of stance on quickness out of the batter's box and velocity toward first base is warranted.

## REFERENCES

- Adams, G.** Effect of Eye Dominance on Baseball Batting. *Research Quarterly*, Vol. 36, No. 1, 1965.
- Hay, J.G.** *The Biomechanics of Sports Techniques*. Englewood Cliffs, NJ: Prentice-Hall, Inc., 1985.
- Hirano, Y.** Biomechanical Analysis of Baseball Hitting. In: *Biomechanics in Sports III and IV*. Terauds, J. et al. (Eds), Academic Publishers, 1987.
- Marino, G.W.** and E.G. Noble. Biomechanical Investigation in the Selection and Preparation of the Canadian Baseball Team. Presented at: Canadian Association for Health, Physical Education and Recreation Annual Conference. Toronto, Ontario, 1983.
- McIntyre, D.** and E. Pfausch. Kinematic Analysis of the Baseball Batting Swings Involved in Opposite Field and Same Field Hitting. *Research Quarterly for Exercise and Sport*. Vol. 53, No.2, 1982.
- Messier, S.** Biomechanical Analysis of the Softball Stride. *Athletic Journal*, August, 1984.
- Messier, S.** and M. Owen. Bat Dynamics of Female Fast Pitch Softball Batters. *Research Quarterly for Exercise and Sport*. Vol. 55, No. 2, 1984.
- Messier, S.** and M. Owen. The Mechanics of Batting: Analysis of Ground Reaction Forces and Selected Lower Extremity Kinematics. *Research Quarterly for Exercise and Sport*. Vol. 56, No. 2, 1985.
- Shapiro, R.** Three Dimensional Kinetic Analysis of the Baseball Swing. Unpublished doctoral dissertation, University of Illinois, 1979.
- Thomas, T.** Hitting the Ball Where It Is Pitched. *Coach*, January, 1987.