

INTRODUCTION

During the maintenance of equilibrium the body is always moving to some degree. The psycho-physiological control system by way of multiple bio-feedback makes it possible to maintain or to re-establish the body balance. It results from the visual, vestibular, skin, kinesthetic and visceral sensory sources, as well as the motor system /Johansson & Magnusson, 1991/.

This neuromuscular process is important and necessary to most sport movements, 'working activities and in the elderly for the prevention of injuries /Lichtenstein, Burger et al., 1990/. The study of balance and posture dynamics makes possible to understand reactions to unexpected displacement of the body.

The control of the body segments, the motor behaviour, the posture dynamics and stability suggest the mechanical aspects of investigation in sport movements.

Biomechanical platform has been used by several authors for these measurements. Some other systems, e.g. SELSPOT, TV cameras, also were proposed to employ /Riley, Mann, Hodge, 1990/.

The purpose of this study was to develop methods, which make possible the accurate and quick diagnostic of human balance in neurology, traumatology, orthopedics, rehabilitation and sports.

METHODS

Equipment

A completely computerized system with software has been developed. The equipment includes two ADAM force platforms, special ADDON microcomputer and a personal computer. Transducer with strain gauges and instrumentation amplifiers were used in conjunction with the force platform. In the microcomputer analog multiplexer, sample and hold circuit, A/D converter, EPROM and RAM-s, interface stages are controlled by the microprocessor, which makes it possible to perform the following operations: measuring, storage and the RS 232 interfacing to PC /Fig. 1/.

The following programs have been developed:

- Registration of the personal and functional data for administration of patients,
- Dispersion display of the sampled data during the displacement of the centre of mass on the horizontal plane (with Zoom function and analysis) /Romberg and Unterberger/Fukuda tests/,
- Force displacement diagram, following the vertical force vector movements,
- Force-time diagrams with resulting force and time analysis,

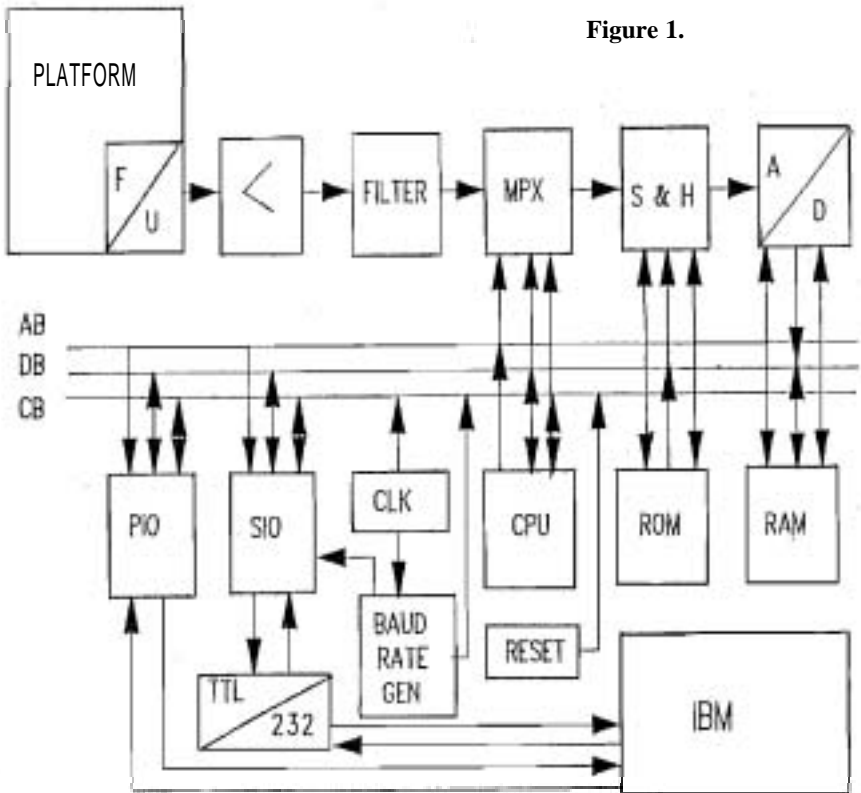

Figure 1.

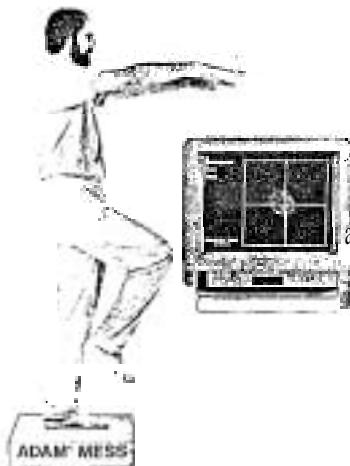

Figure 2.

Stichtgewicht
Schulz
21.11.1955

Bild/F7 = 20x20 cm
Circ/F8 = 1.2 B
Messzeit = 3000 M
F = 885 M

Schwerpunkt
/ 1, 2, 3, 4 /
Ganze Messung

Koordinaten:
X = 27 mm
Y = -18 mm

Radius
R = 43 mm

F5:.....Druck
F6:.....Menu

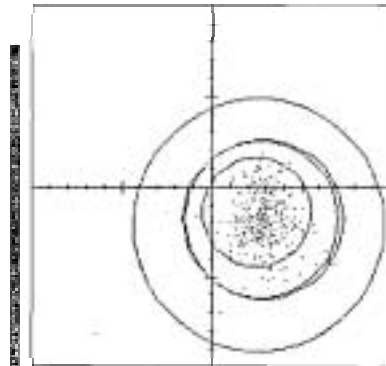

Figure 3.

The battery of tests for the present preliminary experiments are to control the quick diagnostic method which includes the following situations:

- a. standing with feet close together looking ahead and with the arms straight out from the body,
 - b. the same as in "a" but with feet in a position according to the subject's choice /measurements on one or two platforms/
 - c. as in "a" or "b" but with eyes closed,
 - d. the same as aforesaid but in one legged stance.
- /Fig. 2/

Subjects

The investigated persons did not represent a homogeneous group. Sportsmen /active tennis/ and MS patients have been measured /9/, (range 28-65 yrs) for collecting measurements.

RESULTS

The display of results from the quick diagnostic balance test includes the following data and diagrams:

- name and birth date,
 - the dimensions of the covering plate of the force platform or the dimension of the analysed sector,
 - standard deviation statistics and dispersion, (data sampling and determining of the radius of the circle representing the dispersion; r_1 for s , r_2 for $2s$)
68,27 % of the cases are included between $X-s$ and $X+s$
95,45 % of the cases are included between $X-2s$ and $X+2s$ (Cases: sampled displacements)
 - time function of the average displacement of the center of mass,
 - body weight, in analog and digital form,
 - outline of the covering plate of force platform with graduation,
 - the dispersion diagram.
- /Fig. 3/

Excerpta of results.- Sportsmen /4/: average measuring time: 150 s, st. dev.: 34,63. average radius: 0,011 m, st. dev. 0,002.

- MS patients /5/: average measuring time: 44,2 s, st. dev.: 16,86. average radius: 0,062 m, st. dev.: 0,416.

These data were recorded in double leg stance.

DISCUSSION

The computerized force platform system is capable of performing static and dynamic measurements of balance. For an accurate and quick diagnosis, it is necessary to have quantitative evaluation of the measured data as well as an analog representation of the results. The diagnostic equipment we proposed

employs the circle diagram display with coordinates, radius and time data. Further calculations with the stored data are possible. The results of calibration and measurements with subjects made it possible to specify the accuracy of the system. Because of the limited number of subjects, the investigation had a methodological aspect. Nevertheless, the results of two different groups /sportsmen and MS patients/ display limited statistics of balance capabilities.

CONCLUSION

The experiences of preliminary measurements proved the following:

- the use of the ADAM equipment made possible a quick biomechanical analysis of human balance,
- for further investigation the video technics may be used simultaneously to determine the center of mass and to record the body segment movements,
- the circle diagram display and evaluation facilitate the diagnosis, they reflect important parameters of balance,
- for investigation of patients with postural disturbances a flexible time graduation may be proposed. This fact suggests further SW developments.

ACKNOWLEDGMENT

The authors thank Mrs I.Buder-Dahn and Mr.T.Zana for their cooperation.

REFERENCES

- Buder-Dahn I.(1990) Biomechanical Measurements with ADAM platform. In Disorders of Posture and Gait /Ed.: T.Brandt et al./ Georg Thieme Verlag Stuttgart, NewYork, 450-452.
- Johansson R., Magnusson M.(1991) Human Postural Dynamics. Crit.Rev.-Biomed. Eng. 18,413-437.
- Lichtenstein M.J., Burger M.C., Shields S.L., Shiavi R.G.(1990) Comparison of Biomechanics Platform Measures of Balance and Videotaped Measures of Gait with a Clinical Mobility Scale in Elderly Women. J. of Gerontology, 45, M49-54.
- Riley P.O., Mann R.W., Hodge W.A.(1990) Modelling of the Biomechanics of Posture and balance. J. Biomech, 23,503-506.