

INTRA-STROKE BOAT ORIENTATION DURING SINGLE SCULLING

Constanze Loschner, Richard Smith¹ and Margy Galloway
New South Wales Institute of Sport, Sydney, Australia
¹University of Sydney, Faculty of Health Sciences, Australia

It has been established that the amount of yaw, pitch and roll induced in the boat by a sculler, will affect the efficiency of boat propulsion. Therefore, the purpose of this study was to analyse the orientation of a rowing boat (Single Scull) in three dimensions and to relate the results to the rowing style of the sculler. The study will examine the relationship between the boat orientation, the seat and the hand position. In rowing, the movement of the seat and the rowers' body mass influences the pitch of the boat. The roll and yaw of the boat is dependent on the skill level of the athlete and weather conditions. This relationship is a useful indicator for training and performance assessment of athletes.

KEY WORDS: rowing, on-water, 3D boat orientation, sculling, intra-stroke, gyroscope

INTRODUCTION: The speed of the boat (and therefore the athletes' performance) is very dependent on the stability of the boat. Being able to keep the boat balanced around all axes will decrease the water resistance (hydrodynamic drag) and provide a more efficient use of energy in order for the athlete to maintain or increase boat speed. The rower's seat and body mass move along the longitudinal axis of the boat and as a result, the system (boat, athlete and sculls) is unstable. The crossing of the handles during the drive and recovery phase adds asymmetrical elements to the rowing motion and so too does the roll and the yaw of the hull (Wagner, Bartmus, de Marees, 1993). Until the present time, there has only been one study that has examined boat motion in three dimensions. In that paper, only examples of data for two rowers were reported. However, if information related to boat orientation was available, it could be linked with aspects of the rower's technique and ultimately would lead to improvements.

The purpose of the study was to measure boat orientation during single sculling performance and to relate the results to aspects of the rower's body mass and the effect on the rowers' technique and performance.

MATERIALS AND METHODS: Thirteen single scullers were directed to row at four ascending rating steps (20,24,28 and above 32 strokes per minute ($\text{str}\cdot\text{min}^{-1}$)) for 20 strokes each, separated by one minute of light rowing. The athletes were all experienced elite level rowers with the potential to move into the international level over the next two years. The composition of the testing group was as follows: 6 male (2 heavyweight, 4 lightweight) and 7 female (5 heavyweight, 2 lightweight) rowers.

The biomechanical testing boat was set up and was adjusted for each athlete, incorporating their individual requirements (pins, seat, foot-stretcher height, pitch and position). The transducers were all calibrated before each test and the data were sampled at 100 Hz and telemetered to the shore.

The measurements that were used to describe the body movement of the athlete were: the oar angles (electrogoniometer) on both sides mounted over the pin as an indication of hand position and the seat displacement (cable and drum driven potentiometer) as an indication of trunk position. The '*zero-position*' of the seat is where the front of the seat meets the line between the pins (Figure 1). The boat's angular velocity in all three dimensions was measured with three gyroscopes and the boat's linear velocity calculated with a magnetized impeller and coil sensor.

The gyroscopes and the velocity sensor were placed in the centre of the longitudinal axis of the boat. The three dimensions measured were determined as: X-axis (Yaw), Y-axis (Pitch), Z-axis (Roll) (Figure 1).

X-Axis: Yaw
Change of boat direction around the vertical axis of the boat

Negative Value – Bow turns to Bow Side (left side)
Positive Value - Bow turns to Stroke Side (right side)

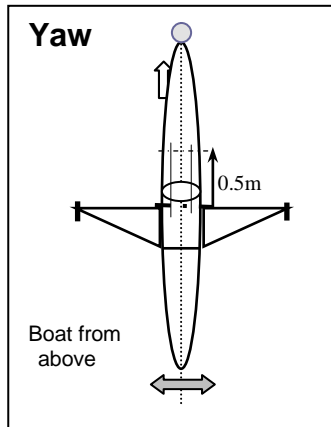

Y-Axis: Pitch
Change of boat direction around the horizontal axis of the boat

Negative Value – Bow goes up
Positive Value – Bow goes down

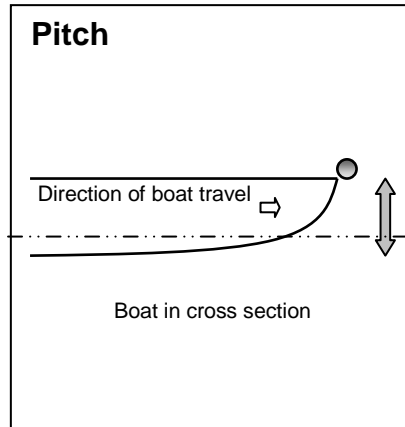

Z-axis: Roll
Change of boat direction around the longitudinal axis of the boat

Negative Value – towards Bow Side (left side)
Positive Value – towards stroke side (right side)

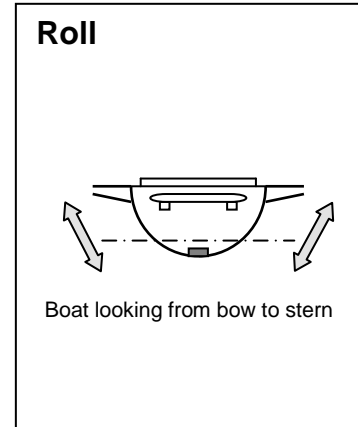

Figure 1 - Definition of boat axes, boat orientation and seat position.

The angular velocity of the three boat directions was integrated to evaluate angular displacement (degrees) with a resolution of 0.1 degrees. The frequency bandwidth was limited to 0.15 - 20 Hz. The whole time series was examined for transient effects of wind gusts, for example, and these sections were excluded from the data analysis. Only the within-stroke changes in orientation for each rower were considered. The data was subsequently normalized to percent of stroke and each rower's strokes averaged.

RESULTS: The rowers weighed between 58 – 85 Kg (75.3 ± 7.88 (mean \pm SD)) (Table 1). All rowers had a similar time series pattern for Pitch (Figure 3) with the heavier rowers tending to have a larger range of pitching than the lighter rowers ($r = 0.68$, $p < 0.001$). The time series for Yaw and Roll (Figures 4 and 5) were more variable in pattern among the rowers.

Table 1 Mean Range and SD of Rowers' Weight, Boat Orientation, Seat Position and Stroke Length

| | Weight kg | Change of Yaw deg | Change of Pitch deg | Change of Roll deg | Seat Position m | Stroke Length deg |
|-------|--------------|-------------------------|---------------------------|--------------------------|-----------------------|-------------------------|
| Mean | 73.3 | 0.5 | 0.2 | 1.7 | 0.61 | 111.4 |
| Range | | | | | | |
| SD | 7.88 | 0.164 | 0.062 | 0.501 | 0.006 | 0.792 |

DISCUSSION: The results of this study indicated the variability of the boat movement in all three dimensions throughout the whole test. Although the timing and amplitude of the leg drive (mean range = 0.61 m, mean SD = 0.006 m) and arm drive (mean range = 111.4 degrees, mean SD = 0.792 degrees) was remarkably similar among all rowers, the boat orientation showed high variability among these athletes. When analyzing the three

dimensions separately, it was apparent that there are some clear differences, which seem to effect the boat's course.

1. **Pitch.** The pattern of the '*Pitch graph*' for all subjects showed the same changes throughout the stroke. The range of motion was from 0.3 to 0.5 degrees. There was a moderate correlation of 0.68 between the rowers' mass and the pitch range of motion. Therefore, about 50% of the variability in pitch motion can be accounted for by the mass of the rower. There are three significant points that relate to the transfer of the body weight (at the first half of drive phase – peak velocity of leg drive; finish of the stroke - release of blades; first half of recovery phase – start of leg drive). The change in the pitch correlates with the transfer of the weight of the athlete and the distribution of vertical forces between the seat and the stretcher. The bow reaches the lowest point during the finish of the stroke and the change of direction of motion of the rowers' trunk.

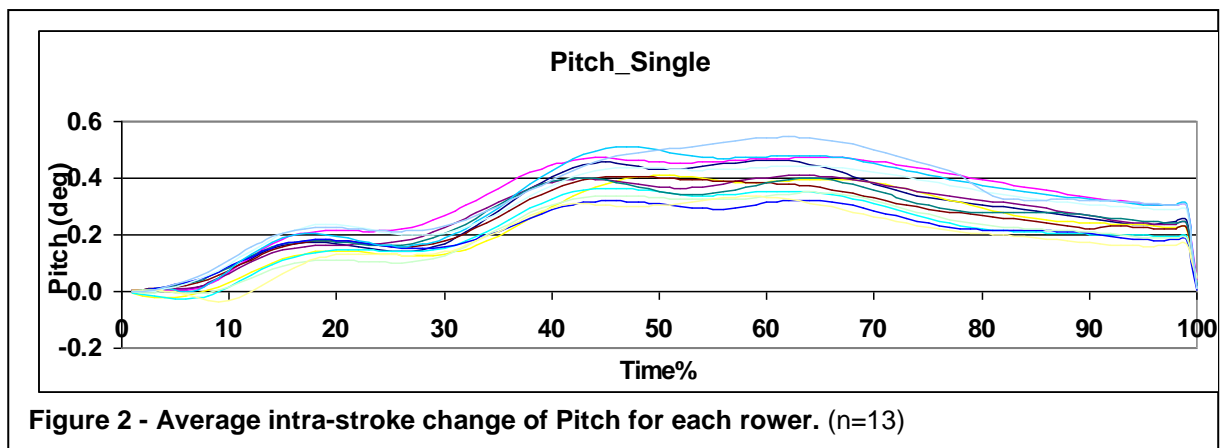

2. **Yaw.** This group of subjects produced a yaw ranging from 0.1 to 0.6 degrees. 0.5 degrees correspond to a 2.5cm. movement at the bow of the boat. The changes appeared particularly during the first half of the drive phase, where the major forces were applied to the blade and the foot-stretcher as well as when the oar handles cross over during the drive phase.

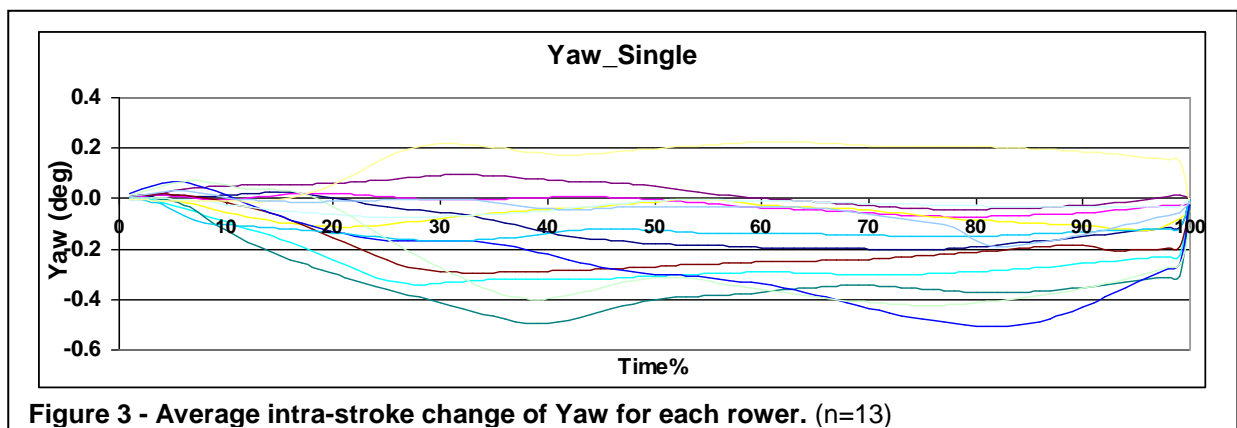

3. **Roll.** The range of direction changes recorded around the longitudinal axis were the highest of all three dimensions from 0.3 to 2.0 degrees. The 'roll' of the boat started just after the catch. Some athletes were capable of keeping the boat very stable around the longitudinal axis.

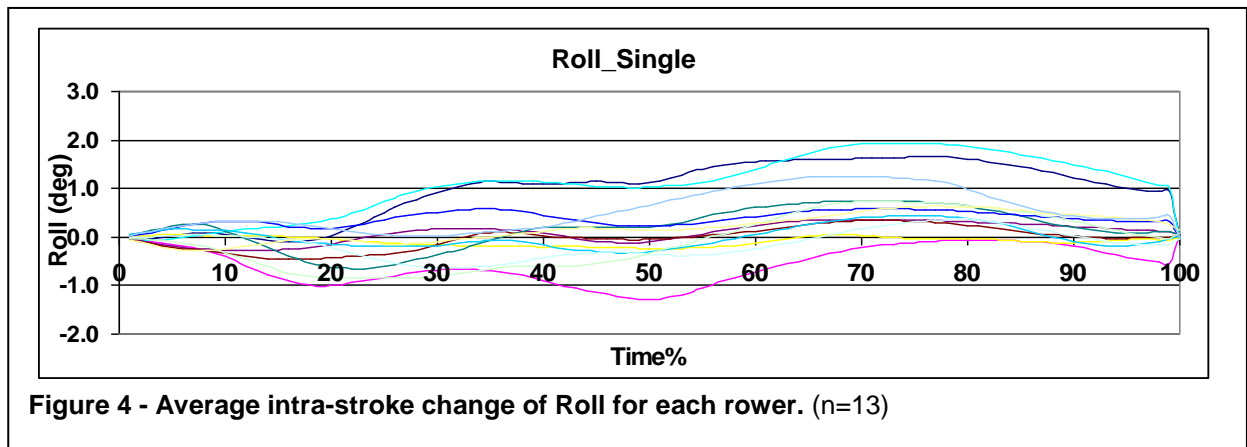

CONCLUSION: The results demonstrate a strong relationship between the boat orientation (Pitch) and the weight of the athlete ($r = 0.68$, $p < 0.001$). However, results point to the need for further investigation into the relationship between the athlete's technique and the changes in orientation of the boat during a rowing stroke.

The time series data must be examined to ensure that transient phenomena such as wind gusts do not affect the averaging process.

Cause and effect connections between the orientation data and boat velocity remain to be established. This will be a complex task as it is difficult to produce Yaw (for example) without affecting propulsion directly.

However, in its own right, information about boat orientation does seem to provide the athletes and coaches with another useful indicator that can be applied during training and performance assessment.

REFERENCES:

Wagner, J., Bartmus, U., & De Marees, H. (1993). Three Axes Gyro System Quantifying the Specific Balance of Rowing. *International Journal of Sports Medicine*, **14**, 35-38.