

METHODOLOGICAL LIMITATIONS OF EMG-BASED BIO-MECHANICAL MOTION ANALYSIS

Thomas Jöllenbeck

Bergische Universität - Gesamthochschule Wuppertal, Germany

The purpose of the present study was to investigate the influence of different methods on the identification of the onset of EMG and force. Using the example of electromechanical delay (EMD), results show a rather distinct dependence of onset times of both EMG and force on the applied method and within the threshold values. However, no automatic method has been found for providing reliable and comparable results. For determination of time sensitive values such as EMD, the visual method seems to be the only advisable method regarding accuracy and reliability. This method provides the earliest onset times, lowest threshold levels and a muscle independent course of EMD related to initial muscle length. For other cases of motion analysis or motor research, with some provision for acceptable inaccuracies of about ± 20 -30ms, this study illustrates why the preferable method should use a moderate low-pass filter and low percentage thresholds.

KEY WORDS: methods, electromechanical delay, EMG-onset, force-onset

INTRODUCTION: Electromyography and dynamography are the only basic methods used in biomechanical motion analysis, providing information about non-visible activities and forces. E.g. lifting a leg from a horizontal position requires a force generation greater than the opposite working gravity before motion becomes visible. Usually, dynamography is limited to the description of a resulting force, electromyography performs valuable assistance in order to show the time, duration and with some restrictions, the degree of activity of a particular muscle participating in motion. Electromyography can provide special meaning in such cases where dynamography is not applicable, e.g. during flight phase in sprint running. Thus, an exact knowledge of the electromechanical delay (EMD) can provide important conclusions for the motion analysis concerning the mechanical effectiveness of a particular muscle which becomes evident via the corresponding EMG. This is achieved by observing the distinct time shift between the onset of electrical activity (EMG) and the onset of mechanical response (force).

However, the exact value of EMD remains a factor of uncertainty because the reported values e.g. for the KE range between 18 ms (Jöllenbeck & Wank, 1999) and 118 ms (Horita & Ishiko 1987). One possible explanation may be that different methods within different threshold values were used to identify the onset times of EMG and force thereby causing methodological differences which are responsible for the uncertainties in EMD (Corcos, Gottlieb, Latash, Almeida, & Gyan, 1992; Jöllenbeck, 1999).

Therefore it was the aim of the present study to investigate the influence of different methods on the identification of the onset times of EMG and force for determination of EMD and finally to show the method shows promise for optimum results.

METHODS: For purposes of this study, data from 140 male subject was used (Figure 1). This data consisted of about 800 explosive maximal isometric voluntary contractions of different investigations of elbow extensor muscle (EE), knee extensor muscles (KE) and knee flexor muscles (KF), KE and KF in part additionally in up to eight different initial muscle length positions

The EMG-time-curves of EE (m. triceps brachii, TR), KE (m. vastus medialis, VM; m. vastus lateralis, VL; m. rectus femoris, RF) and KF (m. biceps femoris, BF; m. semitendinosus, ST) as well as the relevant force-time-curves were digitally recorded with a sampling rate of at least 1 kHz.

Onset times of EMG and force were identified by means of the following methods: visual (VIS), fixed threshold values (FIX), percentage threshold values (PER), standard deviation above mean value as threshold value (STD) and an extreme low-pass filtering (ELF). Additionally, the advantages of previously filtered rectified EMG-data on FIX, PER and STD

by a short-time weighted moving average (MA) and a moderate digital low-pass filtering (LF) procedure were tested (Table 1). This analysis was accomplished with the help of a specially designed computer program.

It is important to point out, that the computer-aided visual method used here performs a zooming function in a plane of about 300x150mm. This monitors a data window of 300 ms width and an extraction of 25% of the maximum values of both EMG and force in order to show the onset of motion as accurately as possible.

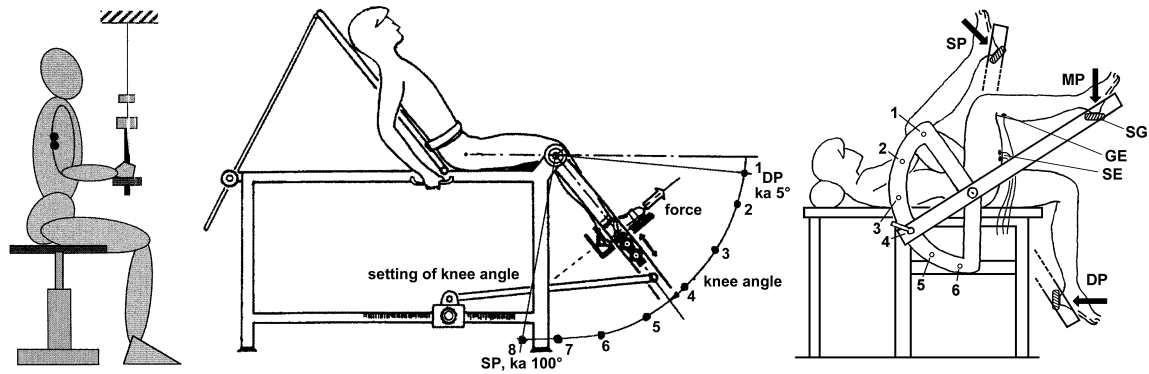

Figure 1 - Experimental station to pick up the EMG- and force-time-curves of EE (left), KE (middle) and KF (right).

Table 1 Methods, Pre-treatments, Threshold Values and EMD, Index i in Ascending Order Related to Threshold Values

| method / muscles | Pre-treatment of EMG and force | EMG threshold | force threshold | EMD [ms] (stdev) from / to | |
|------------------|---------------------------------------------------------------------------------------------------------------------|------------------------------------------------------------------------------------|----------------------------------|----------------------------|--------------------------|
| VIS | Zoomed Window of 300 ms width and 25% of EMG and force maximum value, first continuous onset determines 'threshold' | | | 18,6 (6,6) / 22,0 (8,5) | |
| FIX _i | KE, KF EE | 40 μV, 60 μV, 80 μV 10 μV, 25μV, 50 μV | 2 N, 5 N, 10 N 1 N, 5 N, 10 N | 14,5 (9,1) / 40,4 (12,5) | |
| PER _i | | 3%, 5%, 10% | 1%, 2%, 5% | 24,4 (8,4) / 43,9 (12,7) | |
| STD _i | | SD 3x, 4x, 5x above mean value | | 17,9 (9,7) / 29,8 (14,9) | |
| ELF _i | 3 Hz low-pass | 3%, 5%, 10%, 25%, 50% | | 70,9(11,4) / 112,7(29,8) | |
| FMA _i | KE, KF EE | EMG: MA 16ms, cos ² weighted; force: LF 30Hz, hamming weighted | 40 μV, 60 μV 10 μV, 25μV | 2 N, 5 N 1 N, 5 N | 12,5 (5,8) / 30,9 (12,4) |
| PMA _i | | 3%, 5% | 1%, 2% | 22,6 (7,0) / 37,4 (11,1) | |
| SMA _i | | SD 3x, 4x above mean value | | 26,6 (11,2) / 45,3 (16,1) | |
| FLF _i | KE, KF EE | EMG and force: LF 30Hz, hamming weighted | 40 μV, 60 μV 10 μV, 25μV | 2 N, 5 N 1 N, 5 N | 12,3 (6,6) / 32,4 (12,1) |
| PLF _i | | 3%, 5% | 1%, 2% | 24,6 (6,6) / 42,4 (12,0) | |
| SLF _i | | SD 3x, 4x above mean value | | 27,3 (12,7) / 44,3 (16,2) | |

RESULTS: Despite identical input data, the results (Table 1, Figure 2a) show wide ranging muscle independent EMD values in dependence on the applied method (12,3ms, FLF₁ – 112,7ms, ELF₅). The shortest values of about 20ms and smallest standard deviations are to be found in VIS, longest values of about 100ms in ELF₅, but ELF distinctly exceeds the level

of all other methods. Within a specific method, the shortest values are to be found mostly at lowest threshold values.

Correlating EMD-values between and within methods, only in 6% of all cases, the least acceptable reliability of $r=0.8$ (Willimczik, 1983) is reached, most within a method at different threshold values. Besides no reliable relation is to be found between similar EMD-values and reliability.

Related to different initial muscle length positions (KE, KF) VIS is the only method showing the same constant course for all investigated muscles with shortest EMD in optimal muscle length and an increment in direction of both stretched and not stretched muscle (Figure 2b). Comparing onset times of EMG and force, earliest times were found almost exclusively in VIS indicating the comparatively lowest threshold values. Only a few pre-treated methods show a little earlier EMG-onsets (Figure 3a).

In relation to VIS as the method with earliest onset-times, respectively the lowest threshold values for the over-all standard-deviation on 95% level ($p=0.05$) as one indicator for the accuracy of the best fitting methods, is at least about $\pm 20\text{ms}$ (FIX1, FLF1, PLF1) for the EMG-onset and about $\pm 13\text{ms}$ (FMA1, FLF1, PLF1) for the force-onset. Correlating EMD by varying EMG-onsets and using constant force-onset of VIS, only poor or doubtful reliabilities less than $r=0.8$ were reached. Conversely, with varying force-onsets only a few methods show acceptable reliabilities (FIX1, FMA1, FLF1, PLF1).

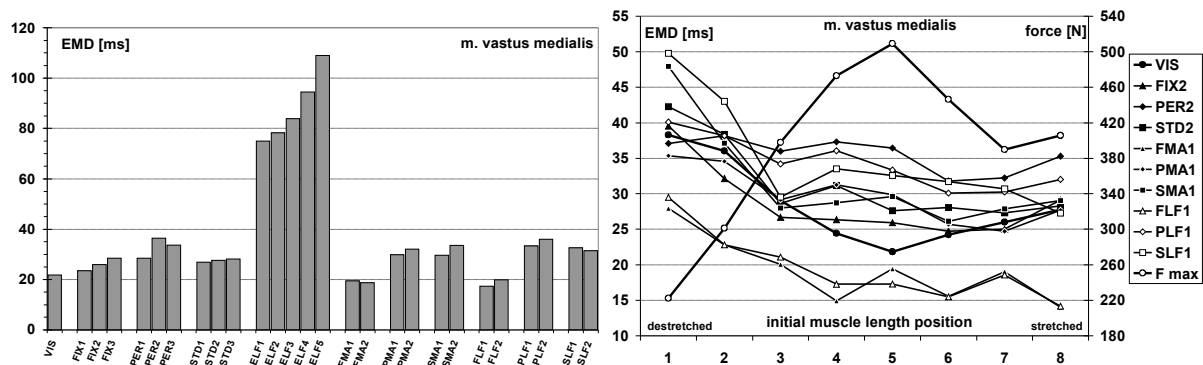

Figure 2 - a) EMD of VM identified by means of different methods (left) and b) in relation to different initial muscle length (right, only selected methods).

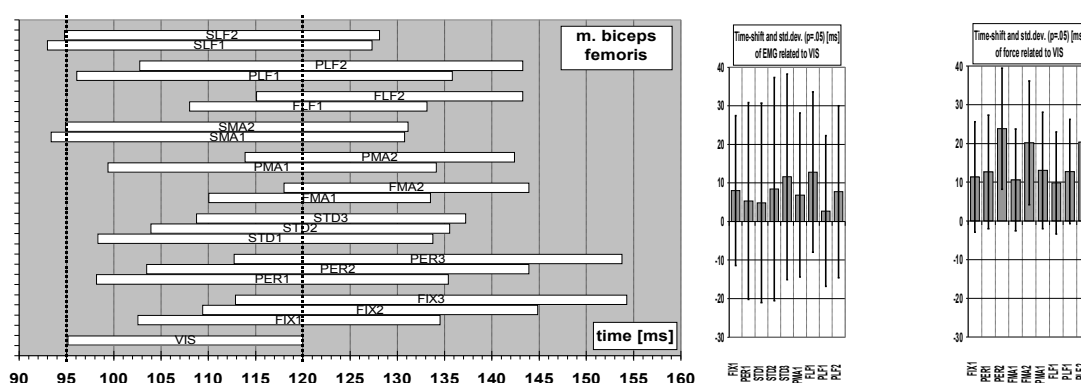

Figure 3 - Time shift caused by different methods a) of EMD (e.g. of BF, left) and b) of EMG- and force-onset related to VIS (right), additionally indicating standard deviation ($p=0.05$).

CONCLUSIONS: Existing results confirm the assumption that applied methods and different threshold values strongly effect the onset-times of EMG and force and therefore also the EMD. Generally, it can be assumed that the higher the threshold level, the wider the time-

shift and later will be the identified onset-times. However, the obvious non-uniformity of the results is surprising, a factor which had not been expected. It is true that results identified by one method may be confirmed quantitatively by the results of another method, but there are no acceptable reliabilities. Considering comparison of the results from identical input data produced by different methods, the acceptable level of reliability between two methods is of special interest rather than the amount of accordance. Precisely the significance of this aspect is missed in most cases. It seems obvious that as a result of different preconditions of analysis, that the given method and within the selected value or level of threshold would lead to different results, independent of whether the determined values are equal or not. So it is to be concluded that different methods for analyzing the onset of EMG and force are not comparable, at least if time-sensitive data such as the EMD are to be investigated. It may be speculated that this could be a possible explanation for some contradictory results or misleading conclusions associated with previous research.

However, analysis of methods revealed further surprising results. It would appear that only the non-automatic method in this comparison seems able to determine the natural and time-sensitive quantity of the EMD with sufficient accuracy and reliability. Without an existing method of reference some indications are responsible for this conclusion. Firstly, the visual method used here shows the earliest comparative times of onset of both EMG and force. This should be equivalent to the lowest threshold values. Secondly, this method is the only one showing the same muscle independent course of EMD related to the initial muscle length. This constancy is not found for any other method. Since there is no reason to suppose that different muscles show different dependencies by varying their initial muscle length, this result has to be considered as an important indicator for the accuracy of the visual method. Thirdly, being different from automatic methods, the visual method is not dependent on the contradictory preconditions of low threshold levels or values and the ability to run automatically with all data. This requires a compromise between both elements and leads to higher threshold levels especially for signals as EMG and therefore a distinct shift on the time scale. Furthermore, the visual examination provides the basic information and preconditions for all automatic procedures and computer-aided analysis.

Ultimately, the visual method seems able to assess accurately between individual conditions and signal characteristics caused by the individual orientated analysis in every single case. This holds true, especially when considering the stochastic character of EMG, which seems to be a performance that is hard to copy using automatic methods.

Even if there seems to be no other possibility than the application of an extensive time-consuming computer-aided visual method to obtain reliable and accurate results for the EMD, there may be other cases in bio-mechanical motion analysis or motor research which are not as time-sensitive as EMD. If a loss in accuracy of about $\pm 20\text{-}30\text{ms}$ is acceptable, some of the automatic methods that have been identified could be appropriate. Results show that force-onset in spite of greater time-shifts can be identified in a more accurate and reliable way as EMG-onset. The three best methods which show only small differences between them are FMA1, FLF1 and PLF1. Showing the most constant results over all investigated muscles, FMA1 offers some advantages. In case of identification, the EMG-onset FIX1 and PLF1 seem to provide the best solutions with comparatively the lowest scattering. PLF1 is the preferred method, if the ability to run automatically is a concern.

REFERENCES:

- Corcos, D.M., Gottlieb, G.L., Latash, M.L., Almeida, G.L., & Gyan, C.A. (1992). Electromechanical delay: An Experimental Artifact. *Journal of Electromyography and Kinesiology*, **2**, 59-68.
- Horita, T., & Ishiko, T. (1987). Relationships between Muscle Lactate Accumulation and Surface EMG Activities During Isokinetic Contractions in Man. *Europ. J. of Appl. Phys.* **56**, 18-23.
- Jöllnbeck, T. (1999). Unsicherheitsfaktor EMD - die Auswirkungen unterschiedlicher Analyseverfahren und Möglichkeiten der Verbesserung. In: WIEMEYER, J. (ed.): *Forschungsmethodologische Aspekte von Bewegung*. Hambury: Motorik und Training im

Sport.

Jöllenebeck, T., & Wank, V. (1999). Electromechanical Delay of the Knee Extensor Muscles and Relation to the Initial Muscle Length. In: SANDERS R.H./GIBSON, B.J. (eds.): *ISBS '99 - XVI International Symposium of Biomechanics in Sports*. Perth: Scientific Proceedings. pp. 125-128.

Willimczik, K. (1983). *Forschungsmethoden in der Sportwissenschaft*. Grundkurs Datenerhebung 1. Hamburg: Verlag Ingrid Czwalina.