

FORCE AND MOMENT MEASUREMENTS DURING ALPINE SKIING DEPENDING ON HEIGHT POSITION

Wolfgang Niessen, E. Müller, Hermann Schwameder,
Universität Salzburg, Austria,
M. A. Wimmer, AO Research Institute, Switzerland,
B. Riepler, Atomic GmbH, Austria

KEY WORDS: alpine skiing, turns, forces, moments, binding plate

INTRODUCTION: For some years it has been usual among alpine ski racers to increase the distance between the running base of the ski and the bottom of the ski boot. For that purpose binding plates are in use. In addition, most of the plates have good dampening properties. Especially in the giant slalom the plates allow ski racers to drive faster. The heights of the plates run the risk of reaching dimensions which seem to be more and more extreme. The injury risk in alpine skiing and particularly in the World Cup event is generally high (Hörterer 1992, Gläser 1995), and for this reason changes in the material are being pursued very critically. The binding plate is said to have negative effects on the moment relations of the knee, because it lengthens the lever arms of the lower leg. As a consequence of an expert opinion by Nachbauer (1996), the F.I.S. limited the maximum height of the binding plates to 5.5 cm.

If a skier descends the slope by turning, he has to fulfill dynamically characterized force balances, and that it makes difficult to calculate the present loading. In addition, the coherence between geometry and generated forces is highly complex, which makes it necessary, in the view of this author, to check theoretically based statements in field studies. Concerning the height position, its influence on lateral moment seems to be the most interesting factor. Only when this moment acts is the ski brought onto the edge and able to maintain this position. Recently it has acquired an important role for the turn initiation phase (compare with Kuchler 1995). Turns performed with body rotation are less important, because modern ski constructions tend to increased side-cuts. For that reason the investigation is restricted to the lateral moment.

In the relevant literature the generation of a lateral moment in cases of edging the skis are reported (Lind, 1997; Wimmer, 1992). Quinn & Mote (1992) determined the forces and torques three-dimensionally for recreational skiers. They also found a lateral moment.

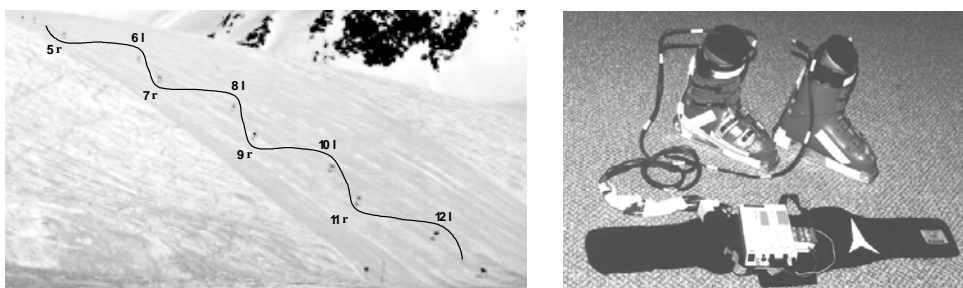

Fig. 1: Trajectory of the eight evaluated turns and measuring system

METHODS: A professional ski racer (A-Kader DSV) descended a giant slalom course (at 25° steepness) nine times consecutively. For all runs the equipment was identical (skis: ATOMIC ARC RS, binding: ESS 10.28) except for the adjusted height of the binding plate. Three different height positions were used. System A was set up without a plate between ski and binding, system B with a plate of 1 cm height and system C with a plate of 2 cm height. Using a previously described measuring boot (Wimmer 1996) the ground reaction forces were determined at four distinct locations underneath the boot soles with bending beams. The bending beams were temperature compensated and allowed the determination of tensile and pressure forces, which were divided into heel medial, heel lateral, toe medial and toe lateral. A fixed bearing at the heel and a movable bearing at the toe avoided constrained forces, which appear when the ski is brought into bending (Wimmer 1996). The data were recorded with a data memory equipment type Biostore (ERNST, Frankfurt, sampling frequency 1000 Hz). The equipment was carried by the skier. The comparison of the force and moment conditions with the turning situation was made by means of video recordings.

RESULTS AND DISCUSSION: In a first step the durations were analyzed. The durations are important concerning the assessment of the force and moment conditions. The standardized conditions of the run and the fixed value of the skiers' body mass cause a direct coherence of the centrifugal force and the velocity ($F_C = m \cdot v^2 / r$). The mean values of the total durations amount to 10.61 sec without plate, 10.23 sec with 1 cm plate and 10.07 sec with 2 cm plate. It can be shown that the skier was faster with a plate. The durations of the 9 runs are visualized in Fig. 2. The black horizontal bars represent the mean values of the different height groups.

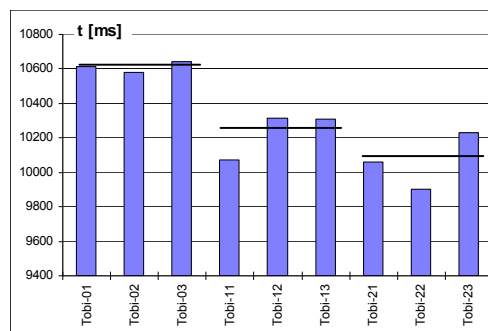

Fig. 2: Durations and mean values

The evaluation of the forces and moments is confined to the respective outside ski, because the force transmission by the inner ski is very poor in the turn steering phase. There are mainly periodic forces, which are probably caused by roughness of the slope or by natural vibrations of the ski. The oscillating kind of the force signals is also named in the literature (Babiel 1996), especially ski vibrations could be recognized with acceleration measurements (Niessen 1996).

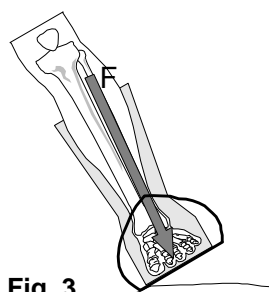

Fig. 3

Forces of the outer ski: The resultant force of the outer ski acting perpendicular to the plane of the ski is calculated by adding up the sectional forces of the four measuring locations. This force is not stationary, i.e., the location point has to be determined later. From the 72 evaluated turns the mean values can be compared in dependence on the height position. The force increases from 1136.5 N without a plate up to 1167.7 N with 1 cm height and 1173.3 with 2 cm height. The maximum forces of the runs reach values up to 2600 N.

Moments: The lateral moment was calculated relating to the longitudinal axis of the ski in the plane of the measuring sensors. The distance of this plane to the running base of the ski is dependent on the selected height position. Analogous to the evaluation of the forces the mean values were determined from the same 72 turns. In dependence on the height position the moments were 33.65 Nm without plate, 35.06 with the 1 cm plate and 36.02 with the 2 cm plate.

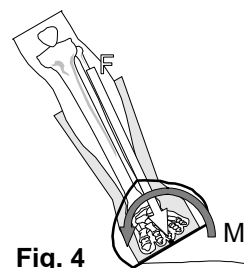

Fig. 4

Calculating the location point of the resultant force: If the lateral moment and force quantity are known, the location point can be calculated. It is the point in the measuring plane where the moments sum to zero.

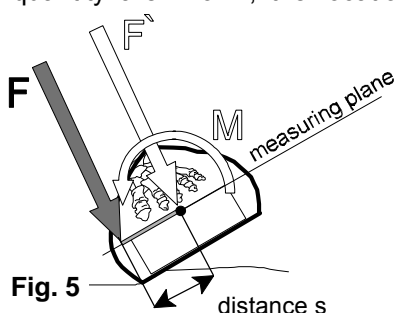

Fig. 5

As for the investigations, only the lateral location was of interest, the coordinates longitudinal to the ski midline were not calculated. From the equation $s=M/F$, s indicates the lateral distance from the longitudinal axis of the ski in the plane of the measuring sensors to the force location point. It was calculated to be 2.96 cm without a plate, 3.00 cm with the 1 cm plate and 3.07 cm with the 2 cm plate.

Location of the ground reaction force: All forces acting on the edge of the ski sum up to the resultant vector of the ground reaction force. In the case of carved turns performed in a giant slalom it can be assumed that the ski bends moderately. Nevertheless the principal share of the forces is applied to the extended section of the binding (see Fig. 6). In a simple model it will be assumed that the resultant ground reaction force is moved by 0.5 cm inside the carved turning radius. This has been applied to all turns in the same way.

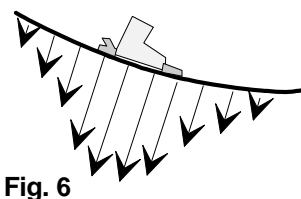

Fig. 6

Angle between resultant force and tibia: The line of action of the resultant force must pass the supposed location of the ground reaction force and the calculated location of the force perpendicular to the measuring plane. The shear force inside the measuring plane would complete the force balance. Because of the supposed location of the ground reaction force the absolute values of the angles may not be exact. Anyway, the differences in dependence on the height position are reproduced in their correct relations. For the system without a plate the value is 8.77°, for the 1 cm plate 6.34° and for the 2 cm plate 4.47°.

Influence of the duration on the results: If the average velocity of the skier is estimated at 15 m/s and if the mean turning radius is estimated at 20 m, the general force can be calculated at about 1200 N. The quantity of this value is comparable with the measured mean values. From the mean values of the durations the speed differences can be calculated. With the equation $F_C=mv^2/r$ and the gravitational weight $F_W=785$ N the mean total force is calculated to 1194 N without plate, 1246 N with 1 cm plate and 1271 N with 2 cm plate. All measured values, or those derived from the measurements respectively, are shown in the table. The calculated forces are listed in the last column.

	<i>velocity</i>	<i>force</i>	<i>moment</i>	<i>distance s</i>	<i>angle</i>	<i>force (calculated)</i>
0 cm	100%	100%	100%	100%	100%	100%
1 cm	103.7%	102.7%	104.2%	101.4%	72.3%	104.4%
2 cm	105.4%	103.2%	107%	103.7%	51.0%	106.4%

In order to eliminate the influence of the duration differences on the results, the measured forces and moments were related to the calculated values. The calculated result of the distance is still the same. This is caused by the fact that the distance is calculated from the quotient of moment and force. Hence the factor of correction is reduced on both sides of the quotient. The angles are calculated purely from the distances and do not change in spite of the time correction.

	<i>velocity</i>	<i>force</i>	<i>moment</i>	<i>distance s</i>	<i>angle</i>
0 cm	100%	100%	100%	100%	100%
1 cm	100%	98.4%	99.8%	101.4%	72.3%
2 cm	100%	97.0%	100.6%	103.7%	51.0%

CONCLUSIONS: Particularly at the moments corrected for time it is obvious that an increase of the moment is not noticeable when using a binding plate. It rather seems that the ski racer always chooses his equilibrium state in the same manner, independently of height position. At any rate, the angle between the tibia and resultant force changes, because binding plates influence the width-height-proportion of ski and binding. The angles in the trials without binding plate are twice as large as with a 2 cm plate. The reduced angulation in the lateral direction could have a positive influence on the load of the knee.

REFERENCES:

- Babiel, S., Hartmann, U., Spitzenpfeil, P., Mester, J. (1997). Ground Reaction Forces in Alpine Skiing, Cross-Country Skiing and Ski Jumping. In E. Müller, H. Schwameder, E. Kornexl, C. Raschner (Eds.), *Science and Skiing* (pp. 200-207). London: E & F Spon.
- Gläser, H. (1995). Wie gefährlich ist der alpine Skisport? *FDSnow* 7.
- Hörterer, H. (1992). Sicherheit bei alpinen Skirennen 1980 bis 1990 - eine kritische Betrachtung aus medizinischer Sicht. *Deutsche Zeitschrift für Sportmedizin* 2.
- Howe, J. (1983). *Skiing Mechanics*. Colorado: Poudre Press.
- Kuchler, W. (1995). *SuperSki - Radikal Radial*. Köln: Echo-Verlag.
- Lind, D., Sanders, S. (1997). *The Physics of Skiing*. Woodbury: AIP Press.
- Müller, E. (1994). Analyzis of the Biomechanical Characteristics of Different Swinging Techniques in Alpine Skiing, *J. of Sports Sci.* 12, 261-278.
- Nachbauer, W., Schindelwig, K., Mössner, M. (1997). Zur Auswirkung der Standhöhe auf Verletzungen im alpinen Skirennensport. Unpublished expert opinion, Innsbruck.
- Niessen, W., Müller, E., Raschner, C., Schwameder, H. (1997). Structural Dynamic Analysis of Alpine Skis During Turns. In E. Müller, H. Schwameder, E. Kornexl, C. Raschner (Eds.), *Science and Skiing* (pp. 216-225). London: E & F Spon.
- Quinn, T., Mote Jr., C. (1992). Prediction of the Loading Along the Leg During Snow Skiing. *J. Biomechanics* 25, 609-625.
- Vogel, A. (1995). Unveröff. Bericht über Ergebnisse von Untersuchungen zur Standhöhe.
- Wimmer, M. A., Holzner, R. (1997). Constraint Forces May Influence the Measurement of Vertical Ground Reaction Forces During Slalom Skiing. In E. Müller, H. Schwameder, E. Kornexl, C. Raschner (Eds.), *Science and Skiing* (pp. 208-215). London: E & F Spon.