

PREDICTION OF FLUID FORCES ACTING ON A HAND MODEL IN UNSTEADY FLOW CONDITIONS

Shigetada Kudo¹, Barry Wilson¹, Toshimasa Yanai² and Hideki Takagi³

¹School of Physical Education, University of Otago, Dunedin, New Zealand

²Life System Science and Technology, Chukyo University, Aichi, Japan

³Institute of Health and Sport Sciences, University of Tsukuba, Ibaraki, Japan

A method to predict resultant fluid forces acting on the hands in unsteady conditions was developed for kinematic and for pressure data for a hand model. The hand model was rotated in the flume. Regression analysis was used to find best-fit equations to predict the resultant fluid forces acting on the hand model. The best-fit equations for pressure and kinematic data were built, and the equation for pressure data was more accurate. The new pressure method predicted more accurately the fluid forces acting on the hand model than the kinematic method and does not require orientation angles of the hand. The mean RMS error in prediction from pressure was 4.2 N compared to 6.7 N from kinematic data ($p < 0.01$).

KEYWORDS: swimmer's hand, pressure method, accuracy

INTRODUCTION: The measurement of fluid forces acting on a swimmer's hand provides a quantitative basis for evaluating the stroke techniques. One of the procedures used to determine the hand force is a cinematographic method (Schleihauf, Gray, & DeRose, 1983). With this method, hand force is calculated from the coefficients of drag and lift (C_d , C_l), the density of water, the velocity of hand and the hand area. This method assumes that fluid forces acting on the hands in swimming are same as the forces acting on the hands when the on-coming flow is steady. However, the movement of swimmer's limbs usually involves acceleration. Pai and Hay (1988) showed that the maximum values of fluid forces acting on an oscillating cylinder were three times greater than that of the fluid forces predicted from static coefficients of C_d and C_l .

Therefore, it is relevant to find a new procedure to predict fluid forces acting on the hands. Another method to predict fluid forces acting on the swimmer's hands, namely the pressure method, has also been developed (Thayer, 1990; Takagi and Wilson, 1999). Thayer found that surface pressures of a hand model were highly correlated with fluid forces acting on the hand model. The method in Thayer's study required the pitch and sweep back angles. Takagi and Wilson showed that the entire pressure of a hand model in steady flow conditions was correlated with eight specific pressure points when using average pressure values over 10 seconds and not instantaneous pressure values. The aim of this study was to develop two methods using kinematic and using pressure data to predict the instantaneous values of the resultant fluid force acting on a hand model in unsteady flows, and to compare the accuracy in predicting the instantaneous values of the resultant fluid force acting on the model for the two methods.

METHODOLOGY: An experiment for this study was conducted in the swimming flume at the School of Physical Education at Otago University. The pressure transducers (KYOWA, Tokyo) were implanted in 12 points of the surface of a hand model based on Thayer (1990), and Takagi and Wilson (1999) studies. The hand model was attached to a load cell (AMTI, Massachusetts, USA). A mechanical system to rotate the hand model was constructed as in Figure 1. A potentiometer was fitted to the rotation axis to measure angular position. The angular position changed in a trial from 35° to 120°. The hand model could be manually rotated about its longitudinal axis that was defined as the orientation angle of hand model. The orientation angle (OA) was defined as OA = 90° when the hand surface on the ventral side was directed to the on-coming flow and OA = 0° when the thumb of the model was directed to the on-coming flow. OA was constant over a trial. However, the pitch (AP) and sweepback angles (SB) changed through a trial because AP and SB were defined as the direction of the on-coming flow in terms of the hand surface (Schleihauf, Gray, & DeRose,

1983), and the hand model in the non-uniform speed moved in the steady flow conditions. The data was recorded at 200 Hz. OA was set from 10° to 170° with 10° increments. The flow velocity in the flume was set at 1.0, 1.3 and 1.6 m/s. The hand velocity relative to the flow velocity in the flume was derived by subtracting the flow velocity in the flume from the hand velocity in the inertial reference frame.

Each trial was conducted 5 times with 4 out of the 5 trials used for building a prediction model and 1 of the 5 trials used to check the accuracy of the prediction model. The static pressure was subtracted from measured pressure data due to flow. In this study fluid forces acting on the hand alone were calculated from the mass of system, the acceleration of the center of mass, the reaction force measured in the load cell and the buoyancy acting on the hand model. Multiple regression analysis was conducted to determine best-fit equations to predict fluid forces acting on the hand model. In the regression analysis with kinematic data at all OA, the prediction models for the three components of fluid forces (drag and 2 lift forces) were built, and the predicted resultant force acting on the hand model was computed from the predicted forces in the 3 components. The velocity of the hand, the acceleration of the hand, AP, and SB were used as kinematic data. Lift1 was defined as the lift force in the direction perpendicular to the rotation plane and Lift2 was defined as lift force perpendicular to drag and Lift1 force. In the regression analysis with pressure data at all OA, the first order of polynomial regression equations, including the interaction among pressures values, were used to build the best-fit equations for predicting the resultant fluid forces acting on the hand model. The average values of fluid forces predicted and measured in each trial were computed. The error in predicting fluid forces acting on the hand model was determined as the RMS value of the difference between the measured and predicted forces. The average values of RMS errors in prediction from kinematic and pressure data were compared between the 2 methods in a t-test.

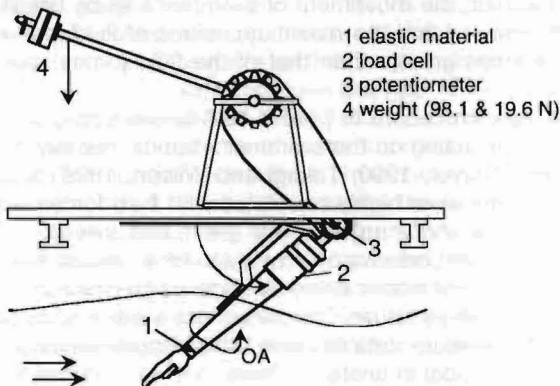

Figure 1 Experimental set-up.

RESULT AND DISCUSSION: The relative hand velocity with respect to the flow in the flume was varied between 0.2 and 4.0 m/s. The acceleration of the model ranged from -13.6 to 22.5 m/s^2 in the direction exerting drag force and from -0.5 to 28.5 m/s^2 in the direction exerting lift force. Some of the predictor variables were excluded from the best-fit equations in the stepwise regression analysis. The adjusted R^2 values for the drag and the two lift forces in the regression analysis of kinematic data were 0.939, 0.528, and 0.876, respectively. The adjusted R^2 value for the resultant fluid force in the regression analysis of pressure data was 0.964. Average and maximum values of predicted resultant fluid forces from kinematic and pressure data, and measured resultant fluid forces are shown in Figures 2 and 3, respectively. RMS errors in predicting the resultant fluid forces from pressure data compared to kinematic data are shown in Figure 4. The resultant fluid forces acting on the hand model when the RMS error in predicting the forces from kinematic and pressure data was largest (15.6 and 9.6 N, respectively) are shown in Figures 5 and 6. The mean value of

RMS errors in the predicted resultant fluid force from kinematic data was significantly larger than the value from pressure data ($p < 0.01$). The pressure method could predict accurately the instantaneous values of resultant fluid force acting on the hand model. The pressure method in this study does not need to use the hand orientation angles, AP and SB, so that it is a practical method for obtaining the resultant fluid force acting on the hand. Future studies are planned to consider the effect of hand size on the best-fit equations for predicting accurately propulsive hand forces.

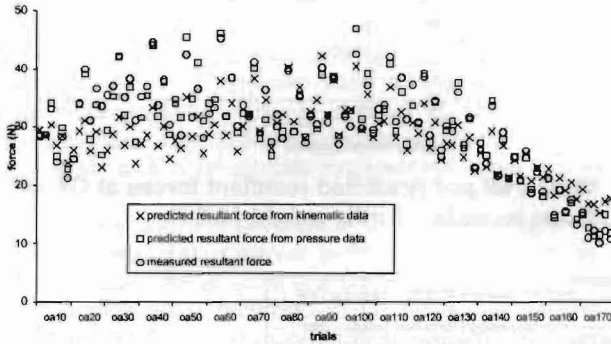

Figure 2 Average resultant fluid forces predicted and measured.

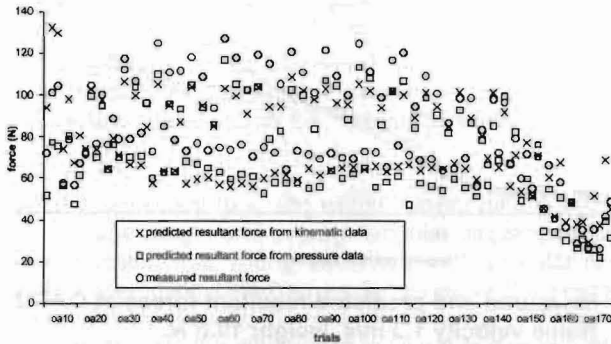

Figure 3 Maximum resultant fluid forces predicted and measured.

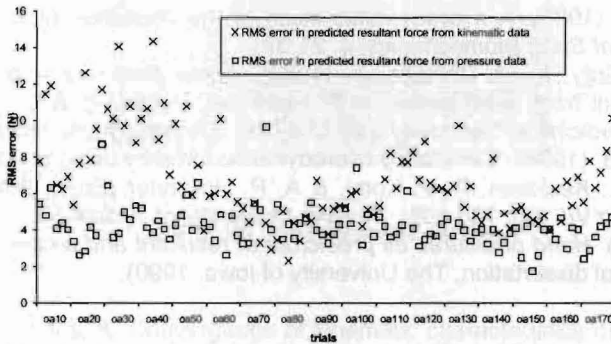

Figure 4 RMS errors in predicting resultant fluid forces.

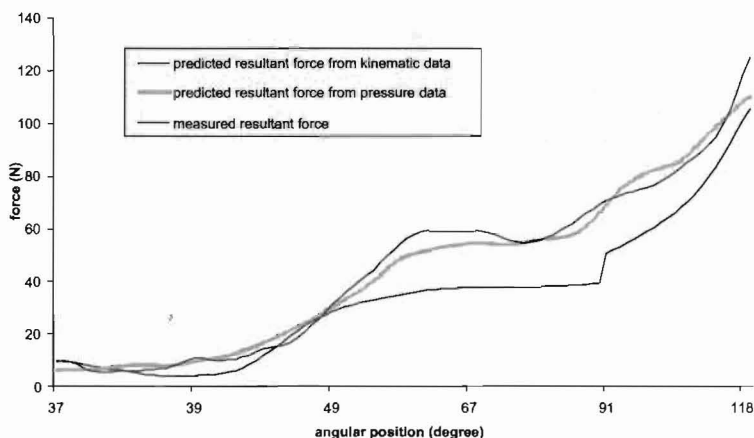

Figure 5 Measured and predicted resultant forces at OA 40°, flume velocity 1.0 m/s, weight 19.6 N.

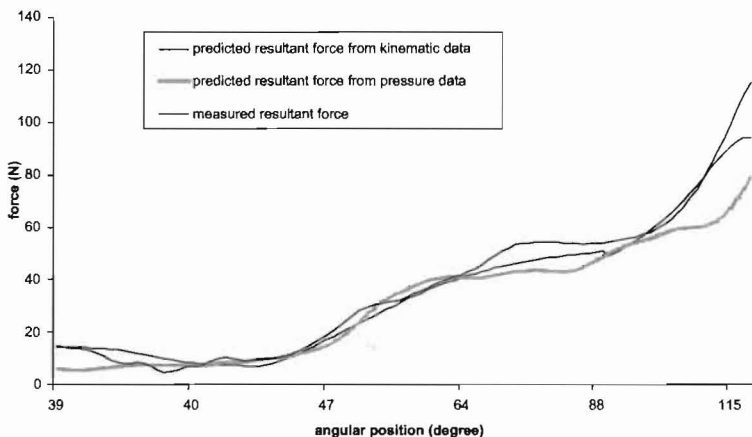

Figure 6 Measured and predicted resultant forces at OA 70°, flume velocity 1.3 m/s, weight 19.6 N.

REFERENCES:

- Pai, Y & Hay, H. G. (1988). A hydrodynamic study of the oscillation motion in swimming. *International Journal of Sport Biomechanics*, 4, 21-37.
- Schleihauf, R. E., Gray, L., & DeRose, J. (1983). Three-dimensional analysis of hand propulsion in the sprint front crawl stroke. In P. Hollander, P. Huijing, & G. de Groot (Eds.), *Biomechanics and Medicine in Swimming* (pp. 173-184). Champaign, IL: Human Kinetics.
- Takagi, H & Wilson, B. (1999). Calculating hydrodynamic force by using pressure differences in swimming. In K. L. Keskinen, P. V. Komi, & A. P. Hollander (Eds.), *Biomechanics and Medicine in Swimming VIII* (pp. 101-106). Finland: University of Jyväskylä.
- Thayer, A. M., (1990). *Hand pressures as predictors of resultant and propulsive hand forces in swimming*. (Doctoral dissertation, The University of Iowa, 1990).

Acknowledgment

The authors are grateful to the School of Physical Education, University of Otago, for financially supporting this research and to Neil Waddell, the School of Dentistry, University of Otago, and Ron Caley, the School of Physical Education, for constructing the apparatus used in this research.